

TENSION CONTROLLER

MODEL LE-40MTA-E

INSTRUCTION MANUAL

Introduction:

- This instruction manual describes the minimum necessary operations and functions for the optimum adjustment of machines by using the LE-40MTA-E tension controller in Sections 1 through 5 taking "One-reel unwinding powder" shown below as an example. Before start setting any systems, thoroughly read these five sections first.
- When mechanism other than "One-reel unwinding powder" is used, read Section 6 "Mechanism other than one-reel unwinding powder" for setting. For the basic items such as the initialization, wiring as well as zero and span adjustment, read Sections 1 through 5.
- When using functions other than the above, read Section 7 "Use of extensive functions" and after.
- Note that this instruction manual is applicable to **system ROM version 3.00 or later**.

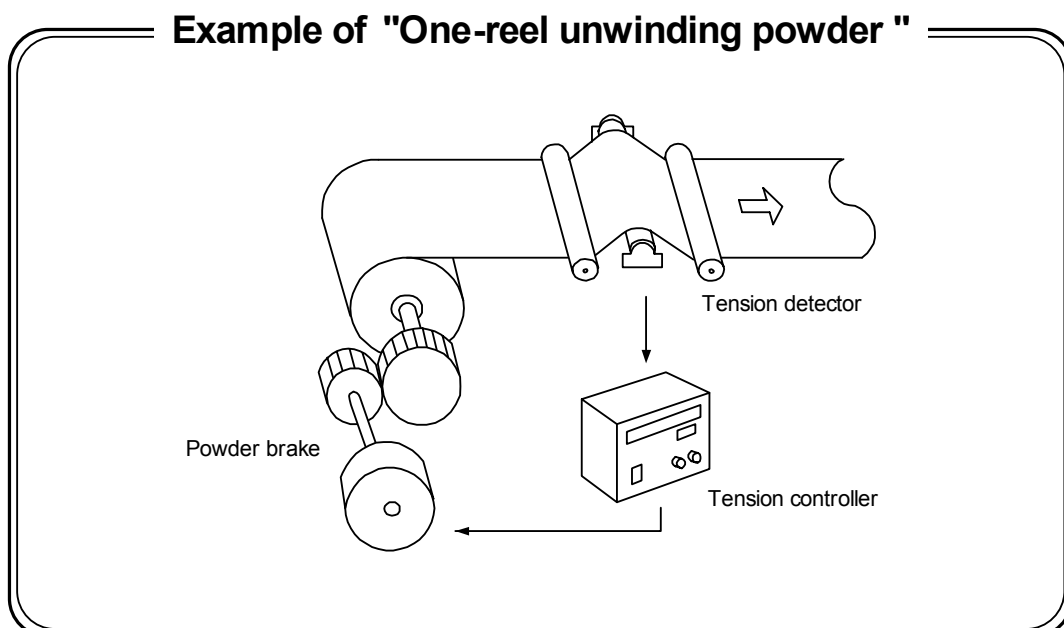



Cautions on Safety



(Make sure to read this page before using the unit .)



To assure safety	
·	Make sure the user thoroughly read this instruction manual before using the unit , and pay attention in assuring safety while using the unit .
·	The unit is manufactured under the severe quality control . When a severe accident or loss is expected in the equipment used due to failure of the unit , provide a backup function or the fail -safe function in the system .



In this manual , cautions of safety are classified into "DANGER" and "CAUTION".



	DANGER: When the unit is handled incorrectly , a dangerous situation may occur and the possibility of death or serious injury is expected .
	CAUTION: When the unit is handled incorrectly , a dangerous situation may occur and the possibility of medium or slight injury is expected or property damage exclusively is expected .



Even an item is classified as "CAUTION", its contents are important and it may lead to a serious result depending on the situation. Make sure to observe every item .



	DANGER Turn off all the phases of the external power supply before starting installation and wiring .
	Otherwise, electrical shock or damage in the unit may occur. Make sure to turn off all the phases of the external power supply before starting installation and wiring.



	DANGER Perform grounding (grounding resistance 100Ω or less).
	Otherwise, electrical shock may occur. Perform grounding (grounding resistance 100Ω or less) to the unit using a wire of 2 mm ² or more, otherwise, electrical shock may occur. Never share the grounding with a strong electric system.



	DANGER Never open the covers while the power is supplied to the unit or when the unit is operating.
	Never supply the power to the unit nor operate the unit while the main body cover and the terminal cover are open. When the covers are open , a high voltage area may be exposed and electrical shock may occur .



	DANGER Never touch a switch with a wet hand .
	Never touch a switch with a wet hand , otherwise, electrical shock may occur.



	DANGER Never drop cutting chips and wire chips while screw holes are tapped and wiring work is performed.
	Damage , fume , fire, malfunction or others may be caused in the unit .



	DANGER Never modify nor disassemble the unit
	Never modify nor disassemble the unit . Otherwise, the unit may become defective or an accident such as fire , damage , etc . may occur.



	DANGER Design the installation plan using the wire size suitable to the current capacity .
	Use the wire size suitable to the current capacity to supply the power to the load . If a wire having smaller current capacity is used, the insulation sheath will be melted and insulation will become defective . In this situation, electrical shock or a short-circuit may occur, and fire may occur .

	DANGER Set up the emergency stop circuit independently of the product .
	Otherwise, the unit may become out of order and an accident may occur when malfunction occurs in the tension controller. Make sure to assemble the emergency stop circuit outside the tension controller .

	DANGER Never use the unit in an atmosphere where inflammation or explosion can occur .
	Otherwise, inflammation or explosion may occur .

	CAUTION Separate the wiring of the strong electric system from the wiring of the weak electric system.
	Separate the wiring of the strong electric system from the wiring of the weak electric system, and make sure that noises are not superimposed on the wiring of the weak electric system. Otherwise, the unit may not operate correctly.

	CAUTION Confirm the ambient environments .
	Never install the unit with an environment where dusts , soot, conductive dusts or corrosive gas is present or a place exposed to high temperature , condensation or wind and rain. Otherwise, the unit may be damaged , malfunction or be deteriorated .

	CAUTION Do not use any unused terminals for any external lines.
	Correctly connect the AC power cable to the specified terminal, and do not use any unused terminals for any external lines. Improper connection may seriously damage the product .

CAUTION

- We shall not be responsible for any damage caused by repair , disassembly, modification, etc. performed by a third party other than MITSUBISHI or a company specified by MITSUBISHI .
- The cautions on safety and the specifications described in the instruction manual are subject to change without notice .

Table of Contents

1. Outline	
1.1 Outline of unit -----	2
1.2 Panel configuration -----	3
2. Mounting and wiring (basics)	
2.1 Caution on mounting -----	4
2.2 Wiring -----	5
3. Operation	
3.1 Setting and change of settings -----	6
3.2 Overall flow of screen -----	7
4. Basics of adjustment and operation	
4.1 Adjustment flow for trial operation -----	8
4.2 Initial setting -----	8
4.3 Adjustment of zero and span for tension detector -----	10
4.4 Automatic operation -----	11
5. Basic knowledge for operation	
5.1 Entering Run/stop signals (use of MC1) --	12
5.2 Use of stall setting (output when operation is stopped)--	13
5.3 Calling up engineer screen -----	15
5.4 Display of operator screen -----	16
6. Mechanism other than one-reel unwinding powder	
6.1 Use of AC servo motor -----	18
6.2 Use of E/P regulator -----	19
6.3 Use for winding operation -----	20
6.4 Use for both winding and unwinding operation -----	20
6.5 Feed reel control -----	21
6.6 Simultaneous multi-reel control -----	22
6.7 Powder unwinding, two-reel switching-	23
6.8 Powder winding, two-reel switching-----	24
6.9 Servo winding and unwinding, two-reel switching -----	25
7. Use of extensive functions	
7.1 Control of excessive sag or tension in material during start and stop-----	26
7.2 Control of excessive sag or tension in material during acceleration and deceleration -----	27
7.3 Control of excessive winding tension Internal reel diameter taper control--	28
7.4 External reel diameter taper control ----	30
7.5 Change of control gains -----	32
7.6 Output of contact when running out of material-----	34
7.7 Use for machines with frequent inching operation -----	34
7.8 Externally turns on or off control output --	35
7.9 Setting of mechanical loss with two-reel switching-----	35
7.10 Use of cut torque -----	36
7.11 Reduction of variation in tension readout	36
8. Use of external analog signals	
8.1 Varies set tension -----	37
8.2 Enters reel diameter data -----	37
8.3 Varies stall -----	38
8.4 Varies taper ratio -----	38
8.5 Varies new reel torque -----	39
8.6 Enters external tension data-----	39
9. Other functions	
9.1 Records tension data-----	40
9.2 Monitors input and output condition ----	40
9.3 Returns all settings to initial factory settings -----	40
9.4 Copies data settings to other controller ---	41
10. Inspection and maintenance	
10.1 Initial inspection -----	42
10.2 Maintenance -----	42
10.3 Error display -----	43
10.4 Unintended operation-----	44
11. Specifications, miscellaneous	
11.1 Input and output specifications-----	46
11.2 External connection diagram -----	48
11.3 Various setting values -----	49
11.4 Select items and analog data-----	50
11.5 Outline dimensions and environmental conditions -----	51
11.6 Supplement -----	52

1. Outline

1.1 Outline of unit

The tension controller LE-40MTA-E automatically controls the tension of a long material during unwinding, use of the feed reel and winding, and is used together with the fine displacement tension detector. The applicable actuators are powder clutch/brake, hysteresis clutch/brake, servo motor (torque mode), and air clutch/brake.

- The tension setting and the manual operation torque usually used by the operator can be adjusted easily using the trimmers provided on the panel.
- The diversified system parameters and operation parameters which must be set by the engineer before operation can be set using the NUMERIC INPUT (increase/decrease) keys while checking the LCD display provided on the panel.
- The automatic zero adjustment function and the span adjustment function for the tension detector as well as the automatic control gain adjustment function for automatic adjustment are offered.
- The operation data can be read and written using the memory cassette FX-EEPROM- 4 (or-8) sold separately.

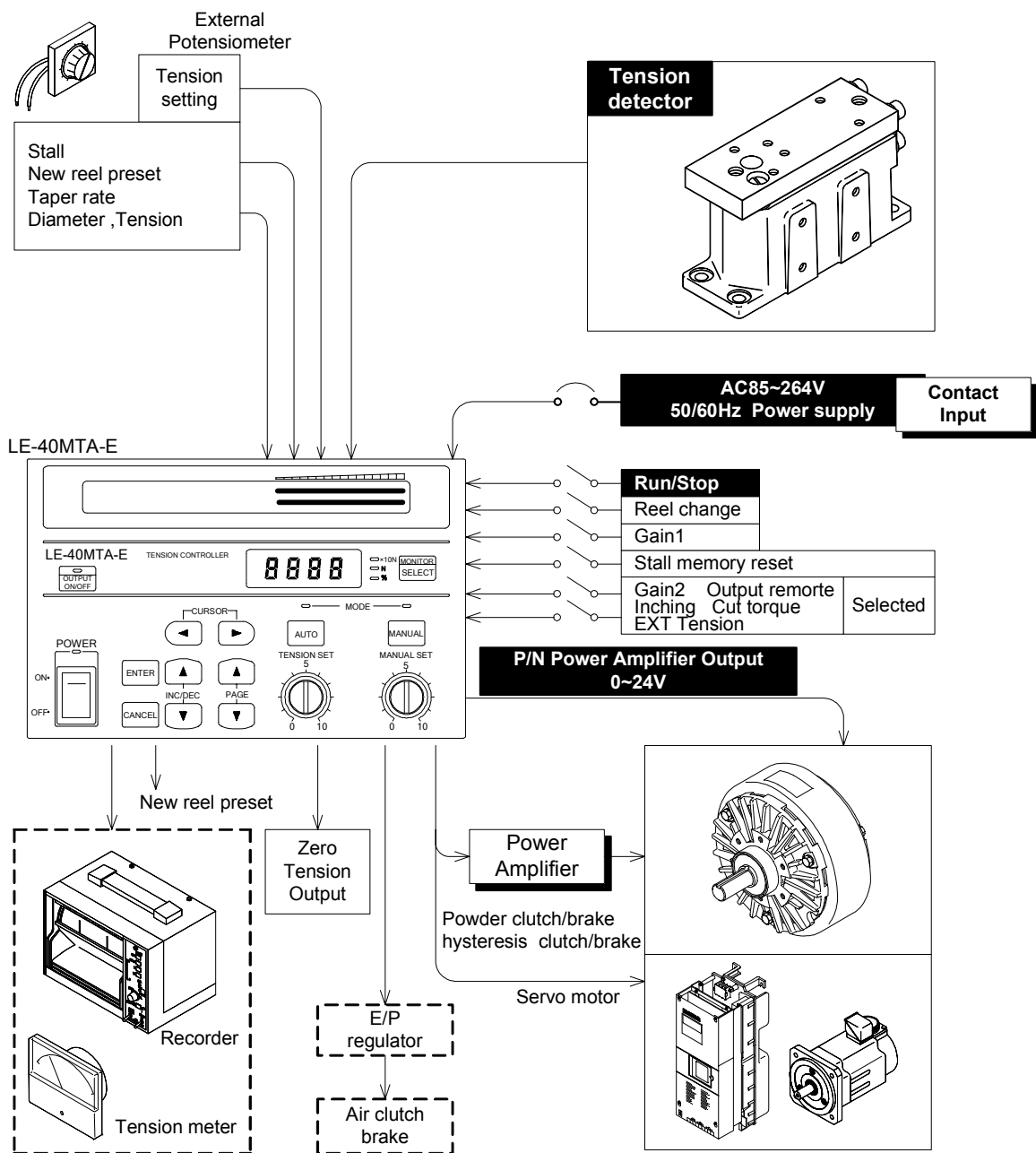

The above external devices may be connected to the input/output terminals of the tension controller. The tension detector, actuator and some of the command input switches (those indicated with white letters on a black background) are mandatory. Other devices are connected as necessary.

1.2 Panel configuration

The figure below shows the configuration of the panel of the tension controller LE-40MTA-E.

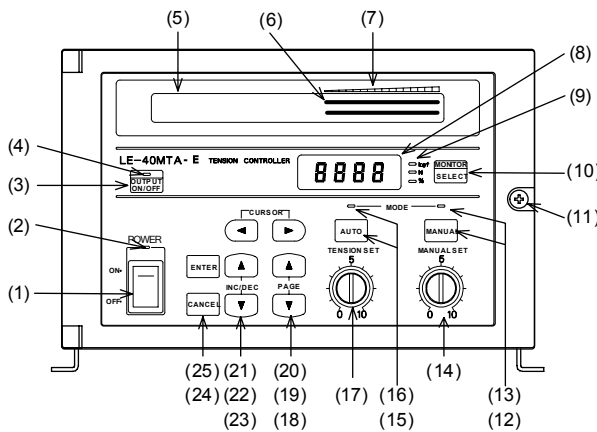

- | | |
|-----------------------------|----------------------------------|
| (1) : POWER switch | (11) : Door open screw |
| (2) : Power LED | (12) : MANUAL mode switch |
| (3) : Output ON/OFF switch | (13) : Manual mode LED |
| (4) : Output ON/OFF LED | (14) : Manual torque set trimmer |
| (5) : LCD display | (15) : AUTO mode switch |
| (6) : Bar graph | (16) : Automatic mode LED |
| Upper : Tension monitor (%) | (17) : TENSION SET trimmer |
| Lower : Target tension (%) | (18)(19) : Screen scroll keys |
| (7) : Scale | (20)(21) : Cursor control keys |
| (8) : Seven-segment display | (22)(23) : Numeric input keys |
| (9) : Unit LED | (24) : CANCEL key |
| (10) : DISPLAY SELECTOR | (25) : ENTER key |
- Tension and output are selected alternately.
Selection of kgf or N is set by the parameter.

1. POWER switch and OUTPUT ON / OFF switch

Turn on the POWER switch and the OUTPUT ON/OFF switch to light the LEDs provided on the upper portion of the both switches.

(Note) Use OUTPUT ON/OFF switch or OUT REMOTE input without using the POWER switch when the output is turned on and off.

- Allowable power switch cycles : 20,000 times

2. DISPLAY SELECTOR switch

The monitored operating tension value is always displayed in the bar graph on the upper right of the screen.

Under the bar graph, the operating tension or control output is displayed in numeric.

The control output or the operating tension is displayed on the seven-segment display in the same way. The type of contents displayed is changed every time the Tension/Output selector switch is pressed. The type of contents displayed on the seven-segment display is indicated by the LED provided on the left side of the selector switch.

The unit of tension ($\times 10\text{N}$ or N) is specified by the setting of the parameter.

3. Automatic operation (Basic operation)

When the AUTO switch is pressed, the unit performs automatic operation. However, automatic control is not performed if the operation/stop input is not turned on.

The tension set value changes from 0 to full scale value in accordance with the scale of the tension set trimmer of 0 to 10.

The full scale tension is set in the initial setting.

When the taper tension is controlled in accordance with the reel diameter, the tension set value subtracted by the taper tension is regarded as actual target tension and used during automatic control.

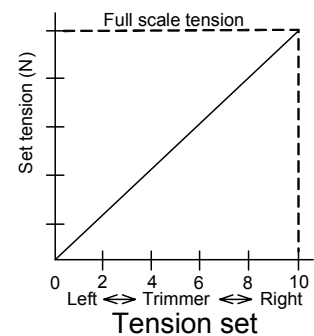

4. Manual operation

When the MANUAL switch is pressed, manual operation is available. The control output of 0~100% can be obtained with the scale of the manual torque set trimmer 0~10. (The output is 0~5V both in the servo mode and the powder mode.)

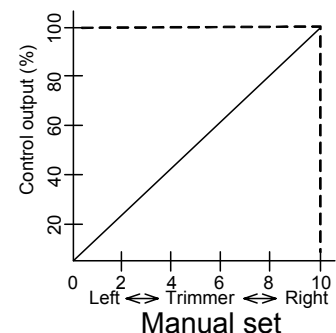

2. Mounting, connection and wiring

2.1 Caution on mounting

DANGER



- Never drop cutting chips and wire chips while screw holes are tapped and wiring work is performed. Otherwise, damage, fume, fire, malfunction or others may be caused in the unit.
- Make sure to turn off all the phases of the power supplies outside before starting installation and wiring.
- Make sure to turn off all the phases of the power supplies outside also before attaching or removing the memory cassette. Otherwise, electric shock or damage in the unit may occur.
- Make sure to attach the terminal block cover offered as an accessory to the unit to prevent electrical shock before supplying the power after the wiring work.

CAUTION



- Never install the unit in a place with dusts, soot, conductive dusts or corrosive gas or a place exposed to high temperature, condensation, wind or rain. Never install the unit directly in a place in which vibration or impact is applied. Otherwise, damage, malfunction or deterioration may be caused.

The tension controller can be installed on the floor, wall or panel surface.

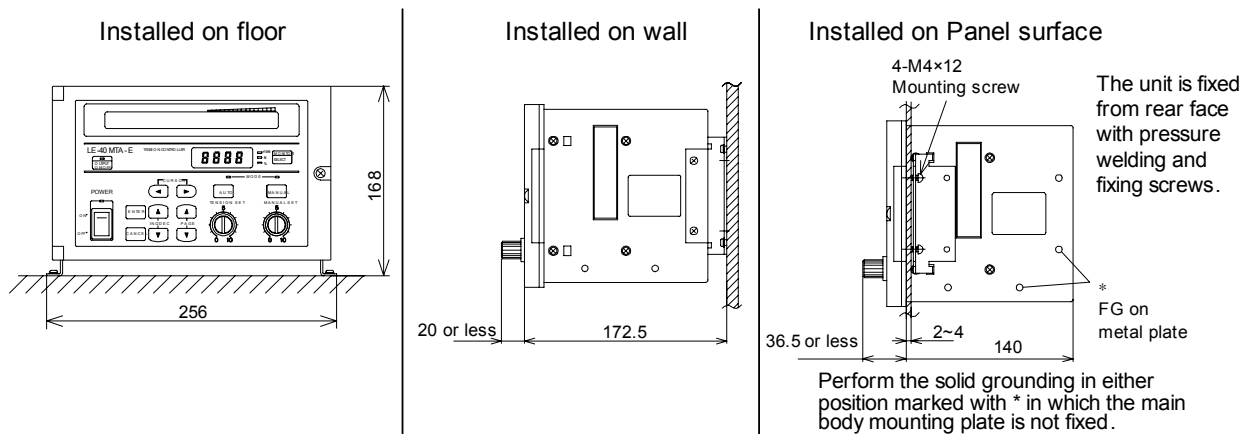

Screw hole dimensions for mounting on floor or wall

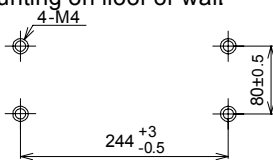

Panel cut dimensions for mounting on panel surface

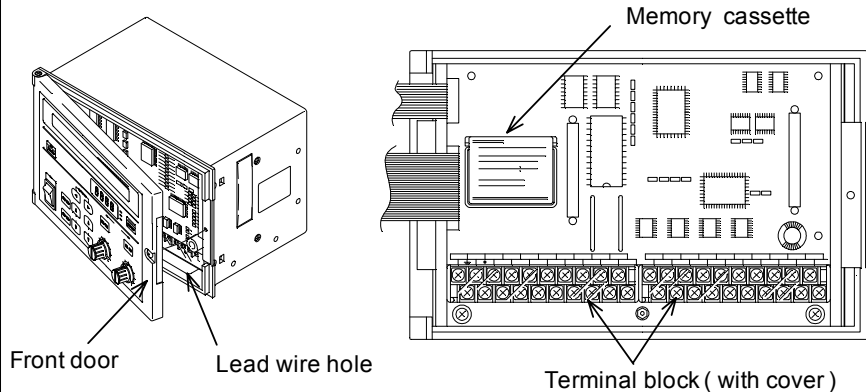
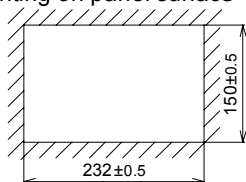

The terminal block to connect external devices is provided inside the box. When the front door is open, the terminal block can be seen. Pull the lead wire out of the box from the lead wire hole provided on the lower portion of the box.

General description on wiring work

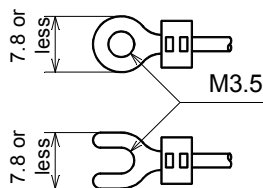

- Use crimp-style terminals whose dimensions are as shown in the figure on the left.
- The terminal tightening torque shall be 0.5 to 0.8 N•m (5 to 8 kgf•cm). Tighten the terminals securely so that malfunction will not be caused.
- Perform Class 3 grounding to the analog I/O cables and the winding shaft pulse input cable with shielded cables on the signal receive side.
- Never let the I/O cables pass through a duct together with other power cables. Never bind the I/O cables together with other power cables.
- Generally, the allowable wiring length shall be 10 m or less to assure safety against noise.

2.2 Wiring

DANGER



- Set the emergency stop circuit outside the tension controller. If the tension controller performs malfunction, the unit may become out of order and an accident may occur in the case in which the emergency circuit is built in the unit. Connect the AC power supply to the terminals PSL and PSN as shown in the figure above.
- If the AC power supply is connected to the I/O terminal or DC supply terminal, the tension controller will be burn out. Do not use the spare terminal for an external device. Otherwise, the unit may be damaged. Perform the solid grounding to the ground terminal and FG using a wire of 2mm² or more.
- Never perform grounding together with the strong power system. Otherwise, malfunction may be caused.

The minimum connection required for the one-reel unwinding are as follows :

1. Connect AC100 to 240V 50/60 Hz power supply to power supply terminals PSL and PSN. The power consumption is 400VA when the output of the power amplifier is at the maximum .
2. Perform the solid grounding to the ground terminals and metal plate according to Class D grounding.
3. Connect the tension detector.
4. If the actuator is a powder type, connect it between terminals P and N. If it is a torque-controllable servomotor, connect it between terminals SA and SN. If it is an electric-pneumatic regulator of 4-20mA, connect it between terminals EAP and EAN.
5. Connect the Run/stop signals to the terminal MC1.

When using other functions, refer to Section 6 and after.

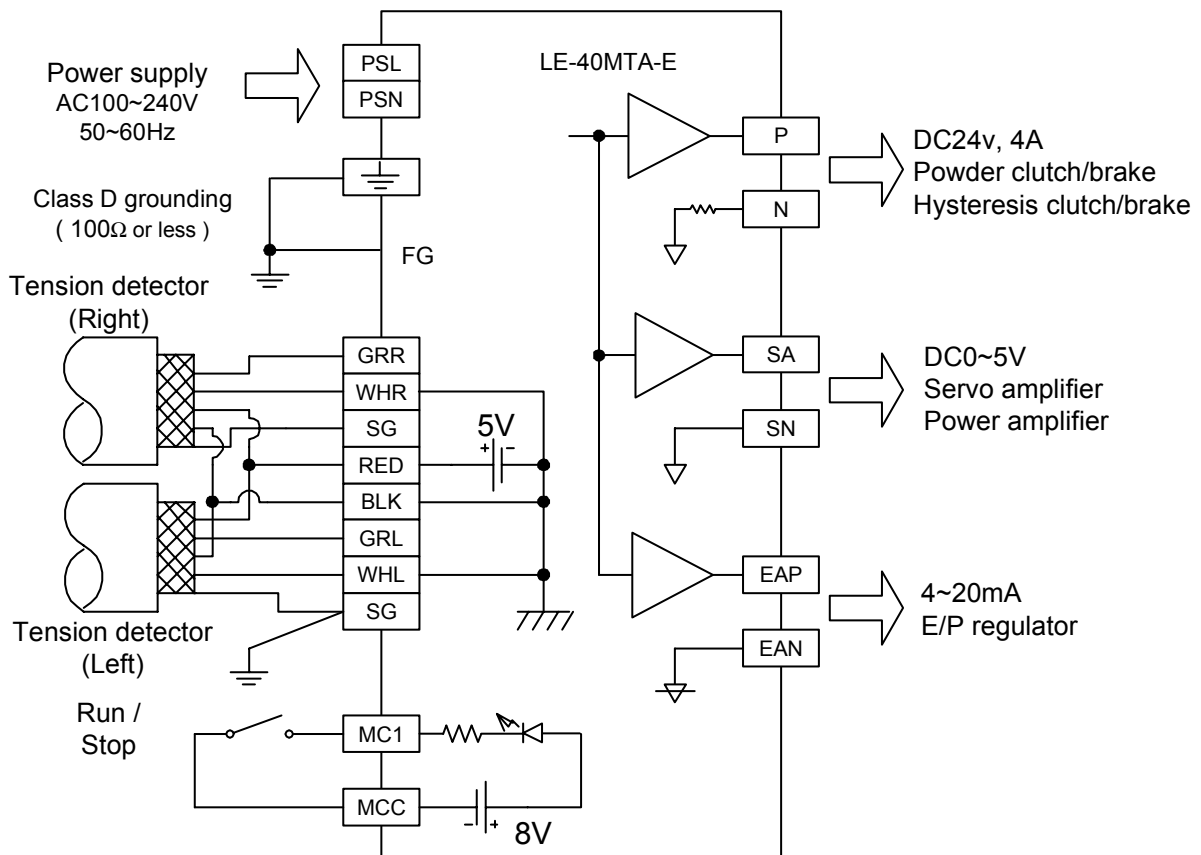

Wiring of Tension Detector

- The figure on the right shows the connection diagram when the load is applied to the detector in the compression direction. When the load is applied in the tension direction, exchange the terminals GRR and WHR each other as well as the terminals GRL and WHL each other.
- When one tension detector is used, connect it to the right side. And make sure to short-circuit the terminals GRL and WHL on the left side.

3. Operation

3.1 Setting and change of settings

1. Selection of item on screen

When two or more items are displayed on the screen, one of them can be selected using the following procedure. The selected item is marked with "■", and held in the memory even while the power is interrupted. When the menu items cannot be displayed on one screen, they can be scrolled and displayed using the cursor control keys (▼▲).

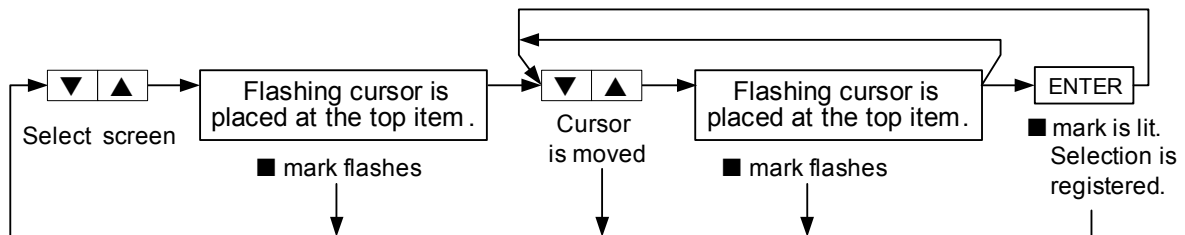

2. Modification of set value on screen

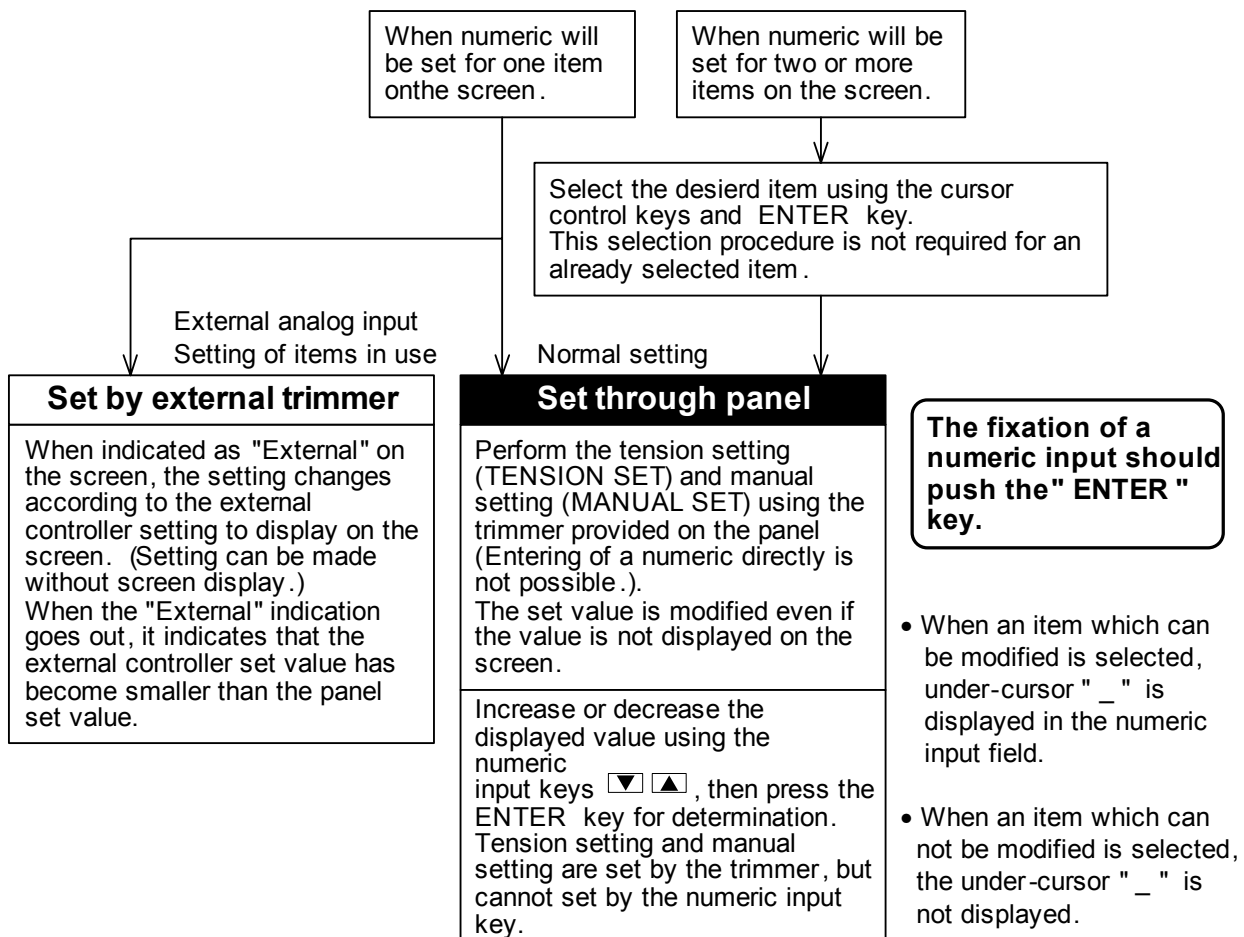

3.2 Overall flow of screen

The figure below shows the overall configuration of screen displays.

The data can be read in turn using the ▼ and ▲ keys.

Four major screens are available. Those are the initial setting screen, operator screen of usual operation, engineer screen for system setting and memory cassette data transfer screen. This section shows the overall flow of the operator screen that is used in usual operation and the engineer screen. For other screens, refer to the relevant sections.

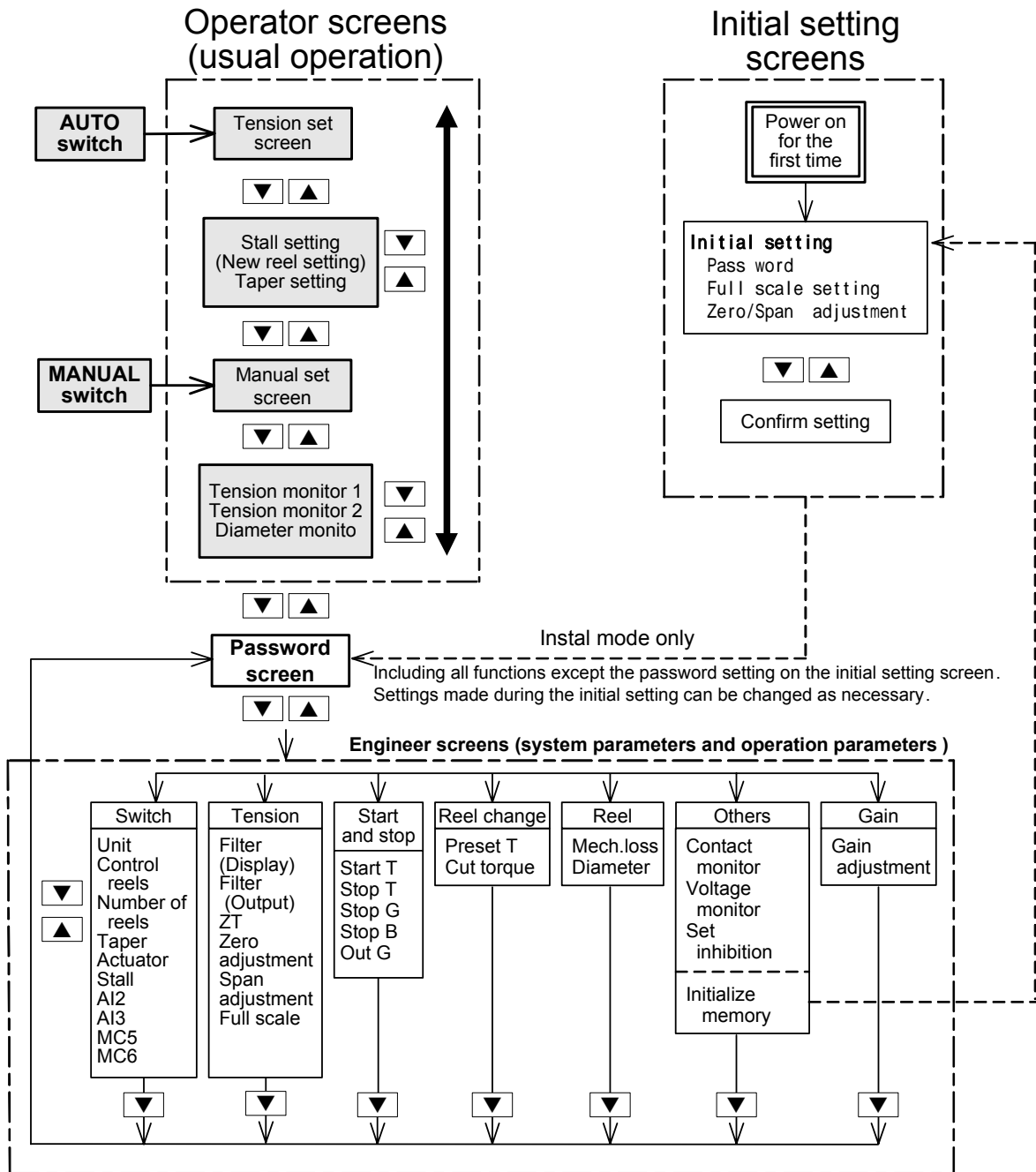

4. Basics of adjustment and operation

4.1 Adjustment flow for trial operation

Carry out the following start-up adjustment as the preparatory step for the automatic operation.

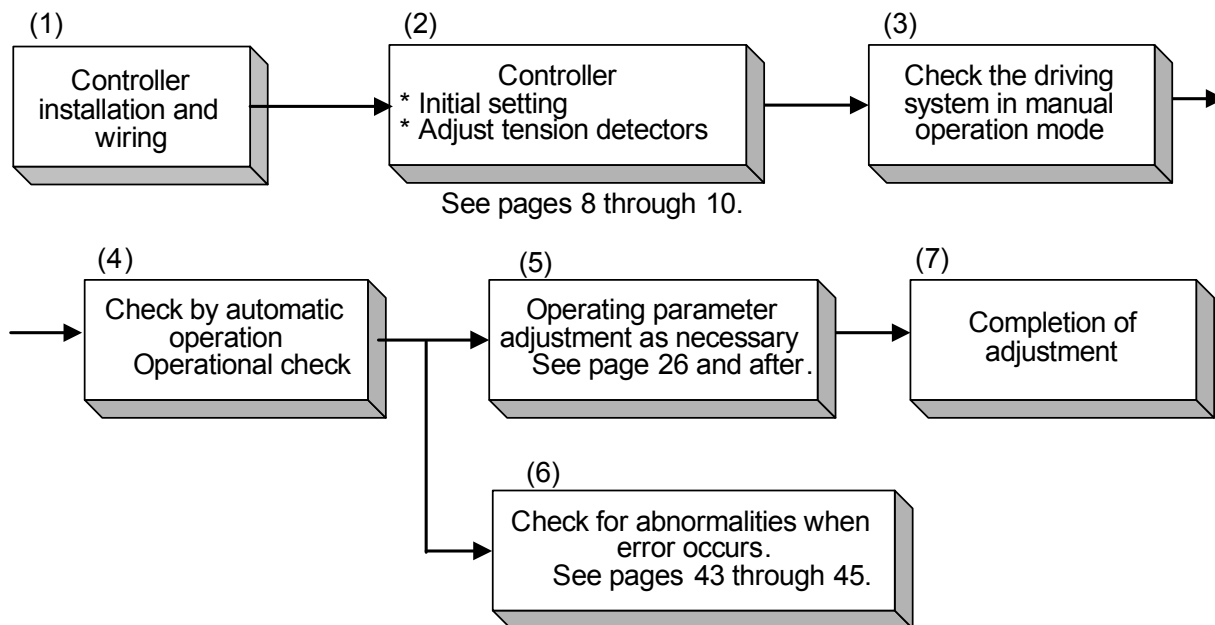

4.2 Initial setting

Select the items using the ◀ and ▶ keys.
 Press the [Enter] key to finalize the setting.
 Then, switch the screens using the ▼ and ▲ keys.
 When the setting of the items marked with "■" is not changed, switch the screens using the ▼ and ▲ keys without pressing the [Enter] key.

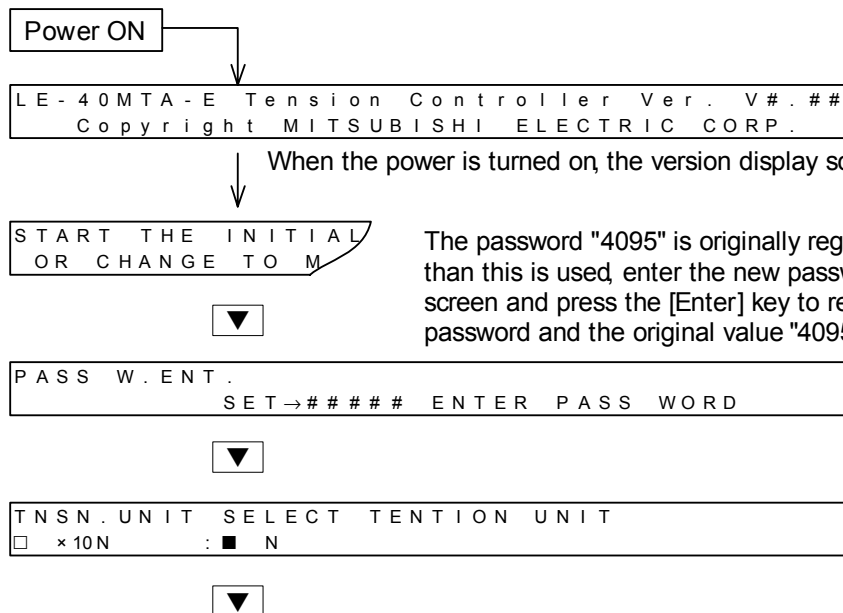

When the power is turned on, the version display screen appears for a few seconds.

The password "4095" is originally registered. When a password other than this is used, enter the new password on the "Password registration" screen and press the [Enter] key to register it. Both the newly registered password and the original value "4095" are valid.

CNTL. PART SELECT REEL OR ROLL
 UNWIND : WIND : FEED

REEL NUM. SELECT REEL NUMBER
 1 REEL : REELS

TAPER SELECT TAPER TENSION CONTROL
 OFF : ON

TPR. DIA. SELECT TAPER SIGNAL
 INT. : EXT.

TAPER MD. SELECT TAPER MODE
 LINEAR : NON-LINEAR

DIA. SET SET DIAMETER
 MIN. DIA → ### #mmφ : MAX. DIA → ### #mmφ

ACTUATOR SELECT ACTUATOR
 POWDER : AC SERVO MOTOR

STALL MD. SELECT STALL SETTING MODE
 KEY SET : MAN. VOL.

STALL RST SELECT STALL MEMORY RESET MODE
 MC4 only : MC4+OUT SW.

A12 SELECT A12 ANALOG INPUT
 DIA. : STALL : NEW R. : TAPER : TNSN.

A13 SELECT A13 ANALOG INPUT
 DIA. : STALL : NEW R. : TAPER : TNSN.

MC5 SELECT MC5 INPUT
 GAIN2 : INCHNG : OUT RMT. : CUT TRQ.

MC6 SELECT MC6 INPUT
 GAIN2 : INCHNG : OUT RMT. : CUT TRQ.

FEED

OFF

INT

- When using the NRO (new reel output), select "Multi-reel" mode. (See page 24 and after)
- Normally, the taper control is not used for unwinding control.

• This is to select whether to use the internal signals of the tension controller or to receive the external reel data to calculate the reel diameter for the taper control. Receiving the external reel diameter results in better taper control accuracy. See page 28 for details.

- Select "POWDER" when using hysteresis or air clutch/brake.
- When using an AC servo, if it is not desired to reverse the direction of torque control between resurrection and power run, select "POWDER".
- This is to select the input method of the stall settings. See page 13 for the details related to stall.
- This is to select the input method for resetting the stall memory. The output on/off switch can also control stall memory reset.
- This is to select AI (analog) input and MC (contact) input. See page 26 and after for the use of these functions. These settings can be made on screens other than the initial setting. It is all right if these settings are made later on.

4.3 Adjustment of zero and span for tension detector

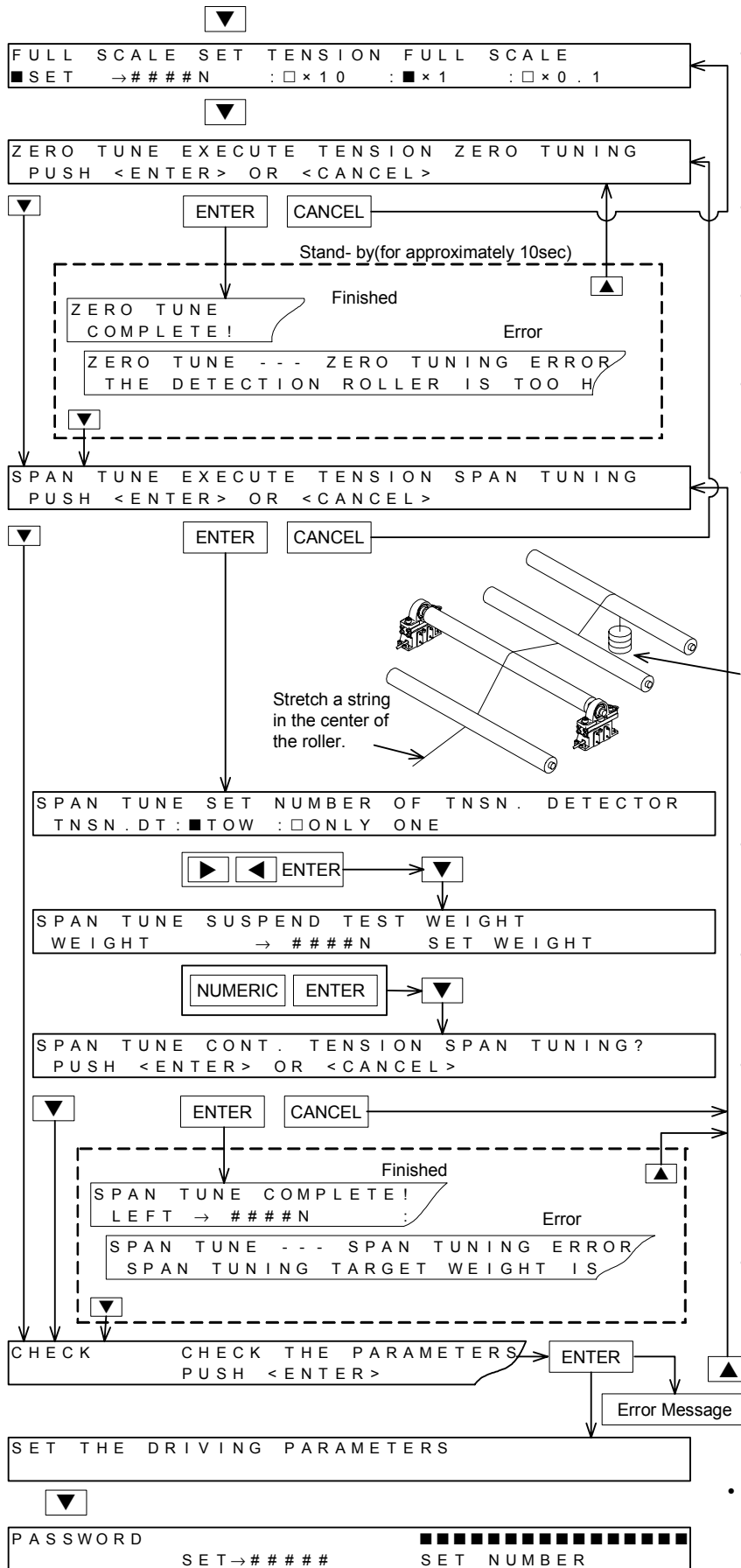

- This is to set the full-scale tension (maximum mechanical tension) and the number of display digits. For example, if desired to have "50.0N" displayed, select "500" and "× 0.1".
- Zero adjustment should be made with the tare weight of the detection reel and without material.
- If unable to make zero adjustment, check the system referring to pages 43 and 45.
- If the tension full scale is changed, carry out the zero/span adjustment again.
- Install the tension detectors on both ends of the detection reel as shown in the left figure. For a short detection reel, only one tension detector may be used. Use the following screen to select one or two tension detectors.
- Suspend weight W (N). The weight should be a static load as close to the full-scale tension value as possible (Should be between 1 to 1/3 of the full scale).
- When, for example, a mass of 10 kg is suspended, multiply it by the gravitational acceleration (9.8) to make it 98N.
- Do not alter the load during the adjustment. Otherwise, the system may not be able to adjust or may generate an error.
- By the display unit setting, the system shows the value in the magnitude of "N" or "×10N". When one tension detector is used, the left display shows zero. When two detectors are used, the left and right readings are balanced.
- When unable to adjust the span, check the system referring to pages 43 and 45.
- If an error message appears, the system can not complete the adjustment. Set the system again.
- **Initial setting completed. The system setting screen appears hereafter. Set the parameters as necessary.**

5. Basic knowledge for operation

5.1 Entering Run / stop signals (use of MC1)

The minimum necessary preparation for tension control is described in "Adjustment flow for trial operation" on page 10.

This section explains the use of start/stop (MC1) contacts essential to the step (4) operational check in automatic mode.

1. Run / stop (MC1 input)

----- Usually on during operation

- The contacts interlocked with the Run/stop operation of the machine (such as the feed motor Run/stop) are connected. Press the automatic mode switch to enter automatic mode. With the MC1 input made and after a lapse of time set in the start timer, the automatic control will start. See the figure on the right.
- When this input is turned off, the stop gain and the stop bias become valid until the stop timer times up. After that, the stall values become valid. (The start timer and stop timer will be discussed later. See the next page for more about the stall.)

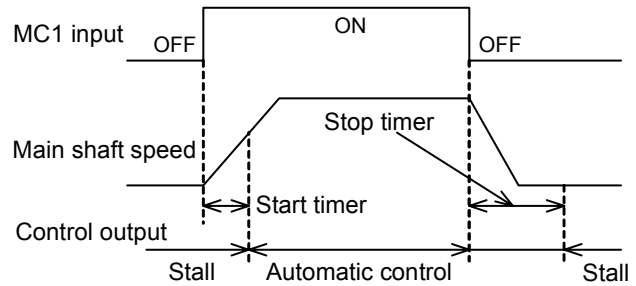

2. Automatic mode indicator lamp

- The lighting conditions of the automatic mode switch, start/stop input (MC1) and the state of the automatic mode indicator are as the figure on the right.

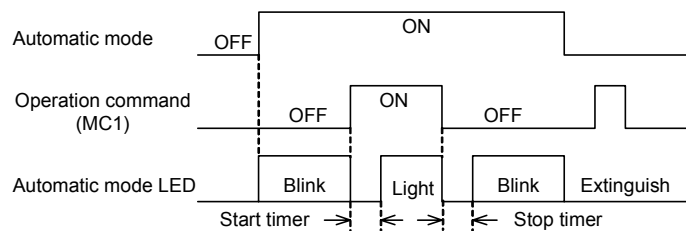

3. Connection

- Use a micro signal switch commensurate with DC8V 4mA as the input contacts. Connect the contacts across MC1 and MCC.

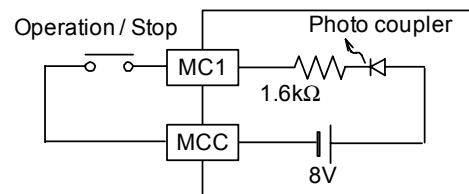

5.2 Use of stall setting (output when operation is stopped)

Stall output is a constant torque given during the automatic control to the machine while it is stationary. At this stage, the feedback control does not take place. This torque is the initial torque for the machine to start with in the automatic control.

- When Run/stop signal MC1 is turned off to stop the material, the stall memory retains the control output values used immediately before the stop. The system resumes the operation using the memorized control output values to stabilize the tension in the material.

The stall memory function is a part of the basic functions, no need to be specially set.

- When changing materials, for example, the stall memory is reset to the output values appropriate to the initial material diameter. These output values are called the stall setting value.

The system uses an EEPROM memory to keep the stall memory values even when the power supply is turned off. No reset operation takes place even when the power supply is turned off or automatic or manual modes switching is performed.

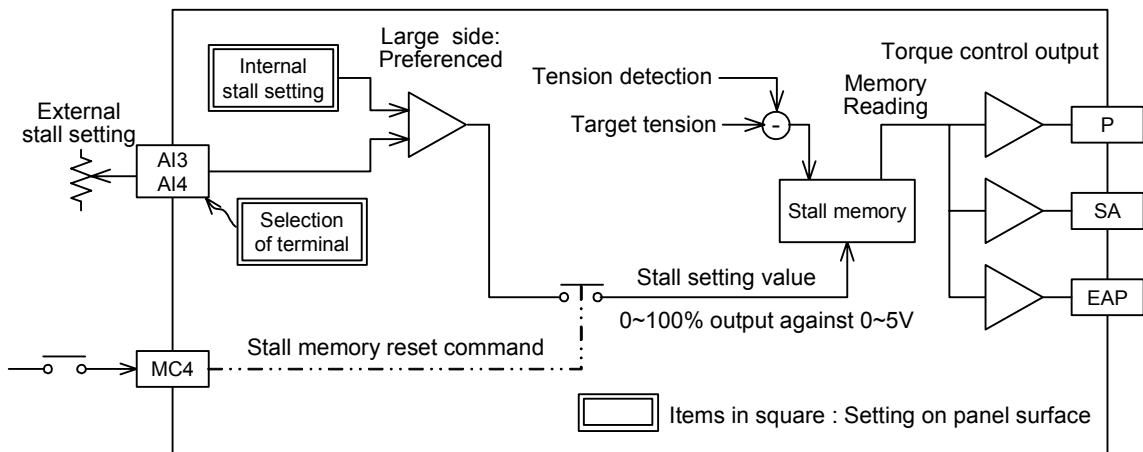

1. Resetting stall memory value

- Two methods are available to reset the stall memory value as follows:
- An output on/off switch is used to reset the stall memory value.
- Stall memory reset input MC4 contacts are used for reset.

In either case, the switch is normally turned on when the reel is changed.

- When the initial setting "MC4 + OUT. SW" at the "STALL RESET" screen is selected (see page 9), the control output is switched from "ON" to "OFF" by the output on/off switch on the panel at the time of changing the material. The stall memory value will be preset to the stall setting value.

- When MC4 is kept "on" for approximately 0.5 second or longer, the stall memory value is preset to the stall setting value.

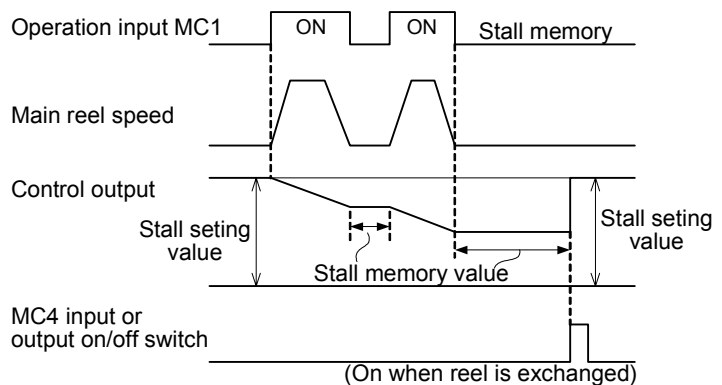

2. Entering stall setting value

- The manual torque controller is used to set the stall setting value in the initial setting. Therefore, the manual torque value will be the stall setting value (stall torque value) in the automatic control.

3. Connection

- To reset the stall memory externally, the MC4 contacts are used.
- Use a micro signal switch commensurate with DC8V 4 mA as the input contact.
- If the stall memory reset input MC4 and MCC are short-circuited, the stall output is always the same as the stall setting value.
- If a signal interlocked with the reel shaft release signal and shaft removal signal is connected to the MC4 contacts, the stall memory can be reset automatically when changing the material.

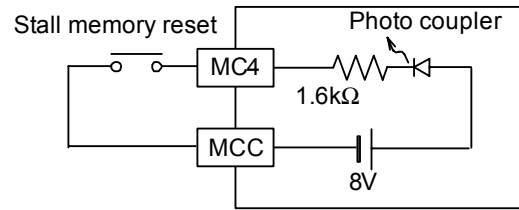

4. Method of entering stall setting value without using manual torque controller

-----A special use of stall function

- In addition to the method by the manual torque controller, following two methods are available to enter the stall setting value.
- Setting by key input on the operator screen
- Setting by external analog input
- To change the stall setting value by key input on the operator screen, use the "STALL MD." screen with "SWITCH" on the initial setting screen or the engineer screen.



- To enter the stall setting value by key input on the operator screen, use the "STALL SET" screen.

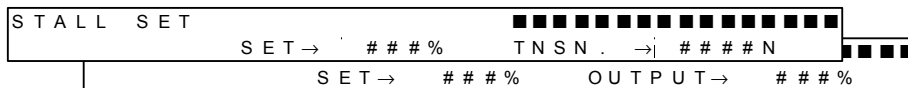

- To change the stall setting value input by the external analog input setting, refer to page 40.

5. Resetting stall memory only by MC4 ----- A special use of stall function

- The system can be set so as to reset the stall memory value only by the MC4 contacts without using the output on/off switch.
- Use the "STALL RST" screen within "SWITCH" on the initial setting screen or the engineer screen.



5.3 Calling up engineer screen

- Follow this operation to make changes from the state of initial setting.
- Enter the password on the password screen. Press the enter key to enter the engineer screen.

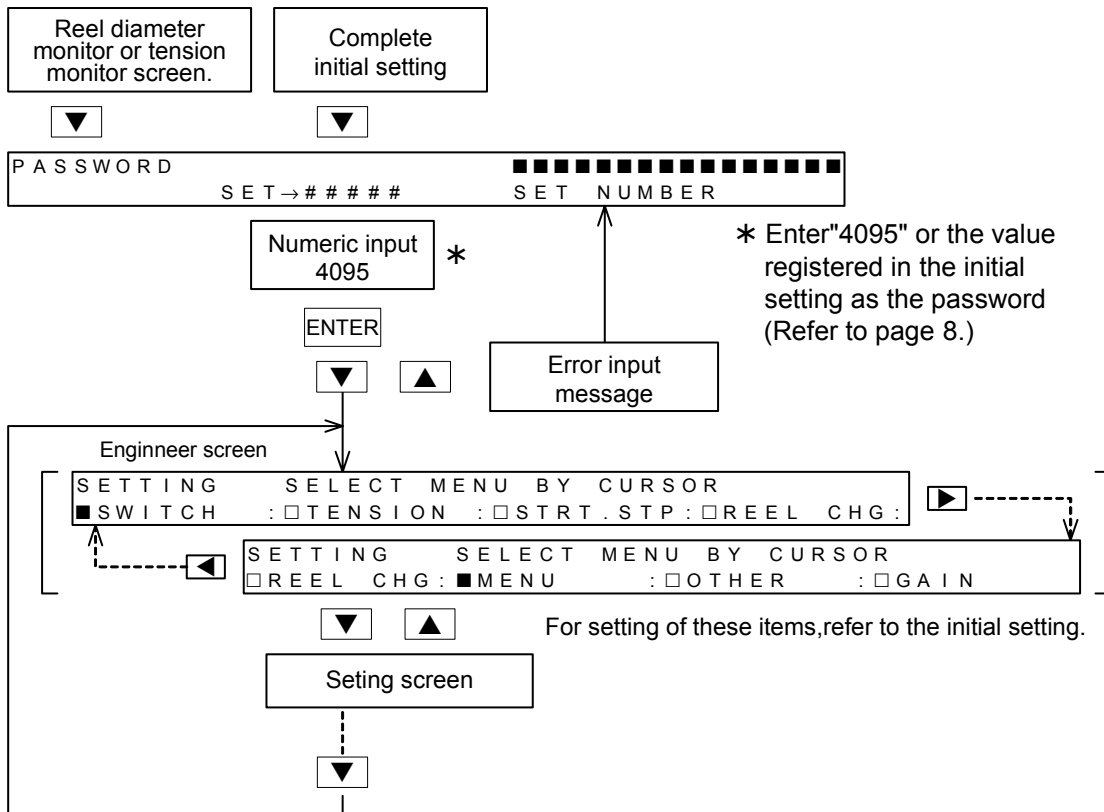

Standard of volume set output

The control output by the manual torque and the stall setting are set by the following standard.

	Feed control	Feed control
Manual torque	$N = \frac{D}{D_{max}} \cdot \frac{F}{F_{max}} \times 100$	$N = \frac{F}{F_{max}} \times 100$
Stall New reel preset	$N = \frac{D_0}{D_{max}} \cdot \frac{\tilde{F}_0}{F_{max}} \times 100$	$N = \frac{\tilde{F}}{F_{max}} \times 100$

Dmax : Maximum diameter
D : Diameter
F : Control tension
D0 : Initial diameter
F : Average drive tension

$$F_{max} = \frac{\text{Ratings torque of actuators}}{\text{The maximum use torque of actuators}} \times \text{The maximum drive tension}$$

- Obtaining stall value and new reel torque by operating actual machine
Operate the machine in automatic control mode with the target tension . Display the output on the output indicator (4-digit, 7-segment display).
Read the output value where the reel diameter is close to the initial diameter . It is recommended to use this value as the stall value .

- The unit of tension (N or × 10N) and the decimal point position are determined by setting the parameter.
- The DISPLAY SELECTOR (TENSION /OUTPUT) switches over the tension display and output display.
- On the screen of Tension set, Stall set, New reel set, Taper ratio, the internal setting or the external setting which is effective is displayed on the screen. When the external setting is effective, "EXT." is displayed on the screen.

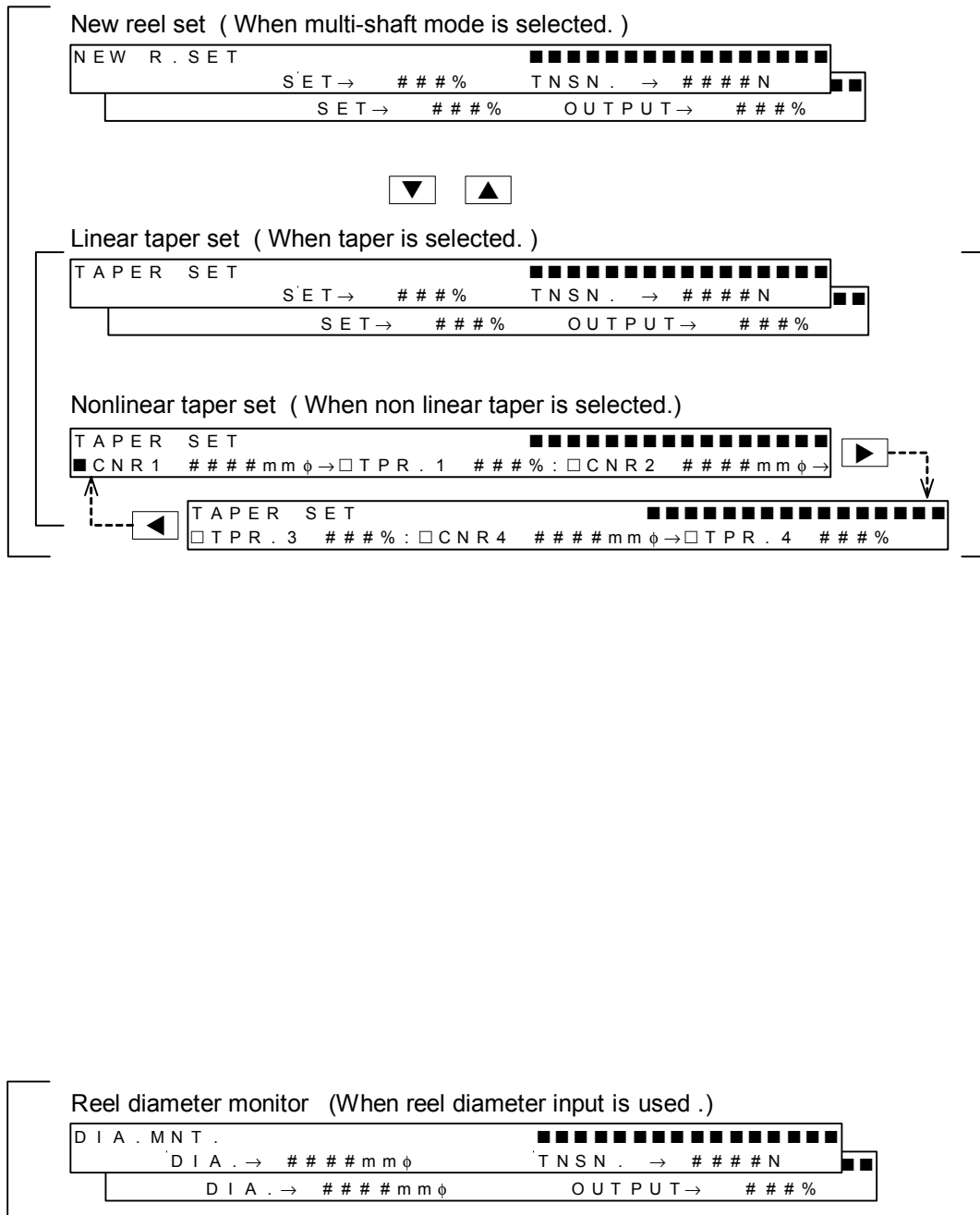

6. To use other than one - reel unwinding powder

6.1 Use of AC servo motor

The system is equipped with the SA-SN terminals for controlling an AC servomotor or a vector inverter motor that can control torque.

The SA terminal can be connected to some servo amplifiers for the simultaneous multi-reel operation.

1. Wiring (example)

■ Provide the torque command input of the servo amplifier with the following input.

- During operation and during normal stop : Torque command SA of the tension controller
- Emergency stop : Output from the braking torque controller

■ Provide the speed limit input of the servo amplifier with the following input.

- During operation and during normal stop : Upper speed limit setting
- Emergency stop : Set the speed limit input to zero.

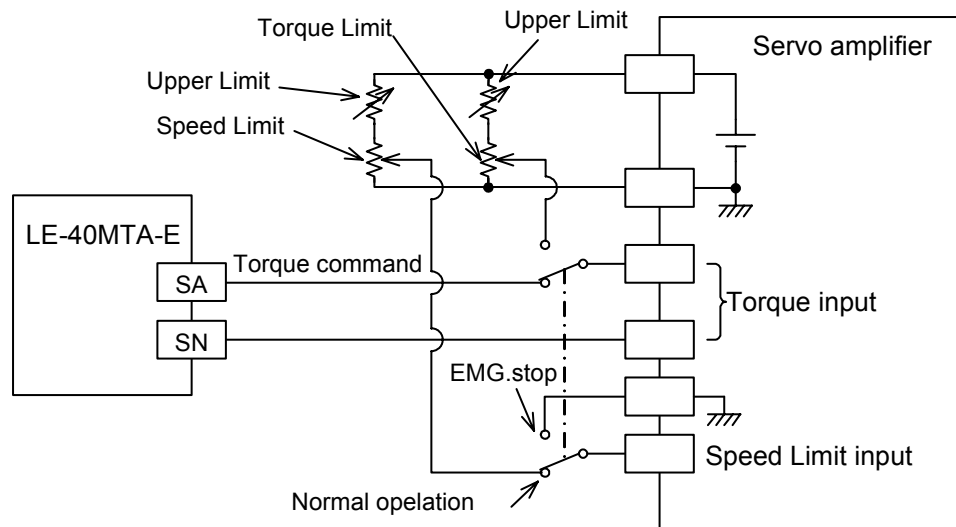

2. Setting

- For the setting, use the "ACTUATOR" screen within "SWITCH" on the initial setting screen or the engineer screen.
- In servo mode, the control values of -100% to 100% correspond to the SA output of -5 to 5V. In powder mode, the control values of 0 to 100% correspond to the SA output of 0 to 5V. The powder mode is completely no problem if the torque is in one direction.

```

ACTUATOR   SELECT ACTUATOR
 POWDER :  AC SERVO MOTOR
    
```

Select "AC SERVO MOTOR".

Handling of servo motor

Setting and changing servo amplifier parameters

With the servo-on input terminal turned off, turn on the servo amplifier power supply. Change the settings of the following parameters.

- Put the servo loop in torque mode.
- Set the system so that the servo motor output torque is equal to the rated torque when the 5V torque command is issued.

For more details of the wiring and setting, observe the servo amplifier instruction manual.

Basic operation check

- Use the upper speed controller to set the speed limit input. Enter the torque command while the tension controller is in the manual operation. Then, check if the motor rotates in the correct direction. Note, however, that the unwinding motor rotates in the correct direction when it reverses, because the material during the unwinding operation pulls it.
- Check that the output torque is adjustable manually to produce the specified torque even when paper is running through the system. In the manual operation, however, the dial readings of zero to 10 on the manual torque controller correspond to the output of 0 to 5 V in the manual operation.

6.2 Use of E/P regulator

When using an air clutch/brake instead of the powder clutch/brake or the hysteresis clutch/brake, the control output of 4 to 20 mA (load resistance to be 470Ω or less) can be supplied to the electric-pneumatic regulator.

The control output of 0 to 100% at this stage corresponds to 4 to 20 mA.

Adjust the zero/span of the electric-pneumatic regulator so that the specified output may be generated in response to the control output of 0 to 100%.

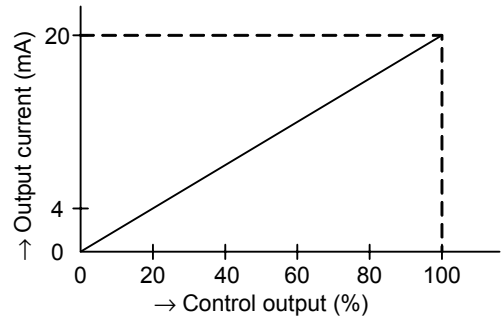

1. Wiring

- When using an electric-pneumatic regulator of 4 to 20 mA input current type, connect it as per the figure shown on the right.
- When using an electric-pneumatic regulator of 0 to 5V voltage input type, connect it between terminals SA and SN.

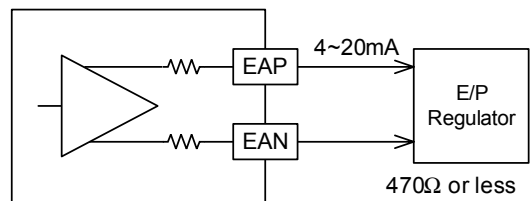

2. Setting

- Use the "ACTUATOR" screen within "SWITCH" on the initial setting screen or the engineer screen to set or change the settings.
- Use this output in powder mode. It can not be used in AC servo mode.

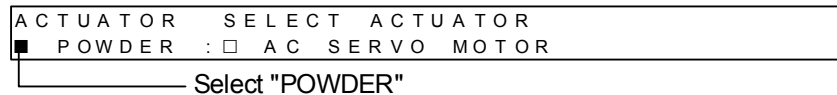

6.3 Use for winding operation

The basic setting and connection are the same as those for the unwinding operation described in up to section 5. Items particular to the winding operation are described below.

Winding control

- The taper control takes place in normal cases to prevent the material from winding too tight. Refer to page 28 and after for the taper control.
- The direction of increasing and decreasing tension in the material in acceleration and deceleration becomes opposite of that for the unwinding control. Refer to pages 26 and 27 for details.
- For the winding operation, the stall setting value and the new reel preset value when switching two reels are relatively small due to a small initial diameter. Refer to page 15 and other relevant sections.
- The winding machine or two-reel switch-over winding machine tends to get effect of significant mechanical loss. To minimize the effect of such mechanical loss, mechanical loss setting is recommended for such machines.

1. Setting

- Use the "CNTL.PART" screen within "SWITCH" on the initial setting screen or the engineer screen to set or change settings.

CNTL.PART	SELECT	REEL	OR	ROLL
<input type="checkbox"/> UNWIND	:	<input checked="" type="checkbox"/> WIND	:	<input type="checkbox"/> FEED

Select "WIND"

6.4 Use for both winding and unwinding operation

There will be no functional differences between the selection of "Unwinding" and "Winding" in the LE-40MTA-E. Therefore, for the switch-over type that functions both as the winder and unwinder, there will be no problem in the winding or unwinding operation. However, observe the following

- The taper control to prevent excessively tight winding is not necessary for the unwinding operation. It is therefore recommended that the taper ratio be controlled externally. Refer to page 28 and after for the taper control.
- The inertia compensation in the acceleration and deceleration operation needs to be changed in between winding and unwinding. Use of gains 1 and 2 is recommended. Refer to pages 26 and 27.
- When performing the taper control with the real diameter over the unwinding operation of the spindleless machine, as the taper reel diameter external, input the winding diameter to A12, 3 input terminals. This allows the taper control to take place on the unwinding side in response to the changes in the reel diameter. Refer to page 28 and after for the taper control.

6.5 Feed reel control

The basic settings and connection are the same as those described up to section 5. Items particular to the feed reel control are described below.

When using an auxiliary brake/clutch for the feed reel, it is convenient to adjust the output manually using the new reel preset output NRO.

1. Connection (powder)

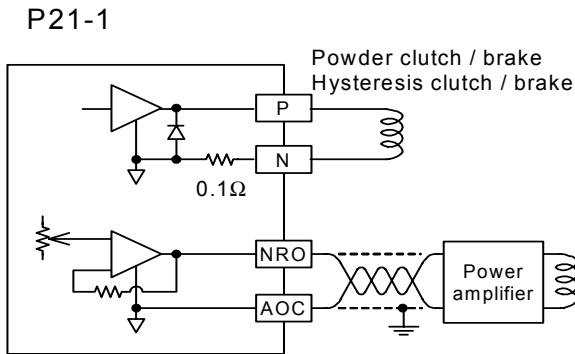

Connect the powder clutch (out feed)/brake (in feed) of DC24V system 4A or less. (The same with the hysteresis clutch/brake in the same manner.)

When the NRO output is used, use the following setting. See page 9.

In feed : Unwinding, multiple reels
Out feed : Winding, multiple reels

2. Connection (servo)

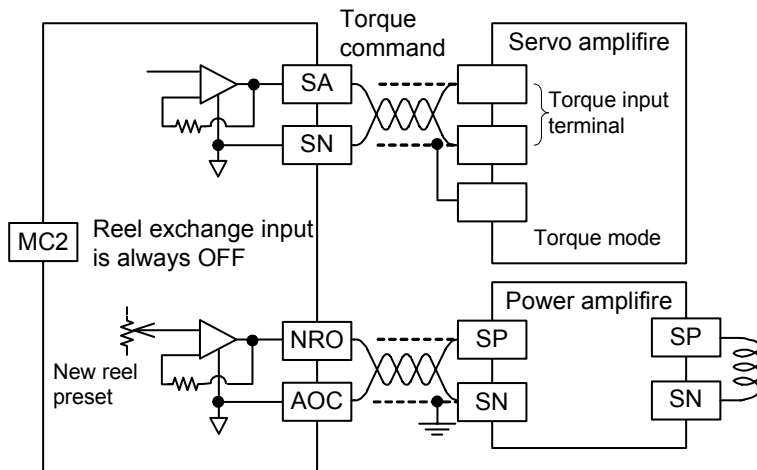

When the servo motor operates both at the resurrection and power running sides, the control may become unstable near zero. In such case, use an auxiliary clutch or brake for the feed reel so that the control output is used either for the resurrection side only or power running side only.

3. Setting

- For the feed reel control, use the "CNTL.PART" screen within "SWITCH" on the initial setting screen or the engineer screen to set as follows:
- When the NRO is used, select "UNWIND" (unwinding) or "WIND" (winding).

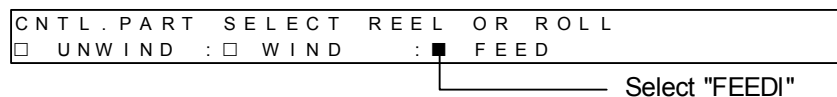

6.6 Simultaneous multi-reel control

When controlling multiple reels by the tension detection from one-reel, the basic setting and connection are the same as those described up to section 5. This section therefore describes the connection related only.

This example is applicable to :

- Cutters to cut off several sheets at one time.
- The machine using two powder brakes simultaneously or one of the two powder brakes because the machine cannot be controlled by one powder brake due to the wide range of torque control.

1. Connection

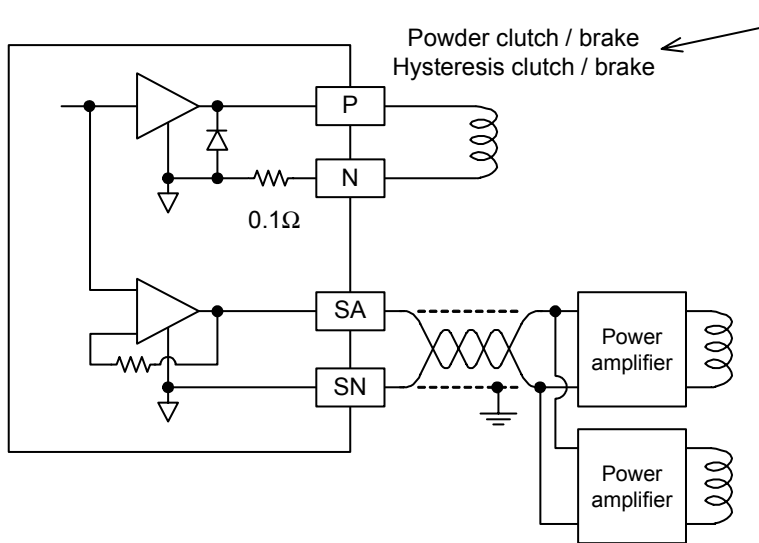

Connect DC24V system powder clutch (winding)/brake (unwinding). Connect the hysteresis clutch and brake in the same manner.

When using two or more powder clutches/brakes, connect them in the manner that the total of the rated current will be 4A or less.

Note, however, that torque variation occurs between the powder clutch and brake.

- When the P-N output is insufficient, up to 10 pcs. power amplifiers for powder clutches and brakes can be connected to terminals SA-SN.
- Two or more servo amplifier can also be connected. Note, however, that the load resistance should be 1 kΩ or greater.
- If the torque variations between the reels need to be restricted, connect an adjusting resistor.
- When connecting an adjusting resistor between terminals P-N, the capacity and resistance should be appropriate.
- When the power amplifier and servo amplifier are connected, adjust the gain on the power amplifier or the servo amplifier as much as possible.

6.7 Powder unwinding, two-reel switching

In the two-reel operation, the contacts interlocking with the reel change are connected to MC2. When this contact input changes from ON to OFF or OFF to ON, the control output is preset to the new reel preset value. When the preset timer times up, the automatic control starts here. Interlock this signal with the cutter operation. Switch SW1 at the same time as SW2 and SW3.

At this stage, as the previous reel is stopped, turn on the auxiliary power supply in a few seconds but not later than 10 seconds.

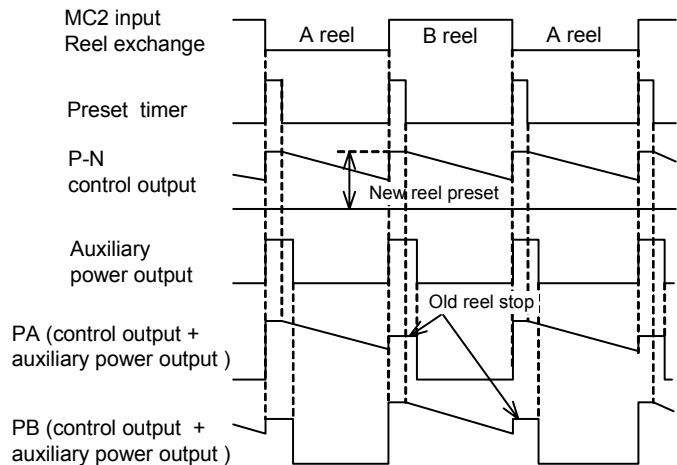

PA and PB is control output for powder to A/B shaft.

1. Connection of switch-over 2-reel powder

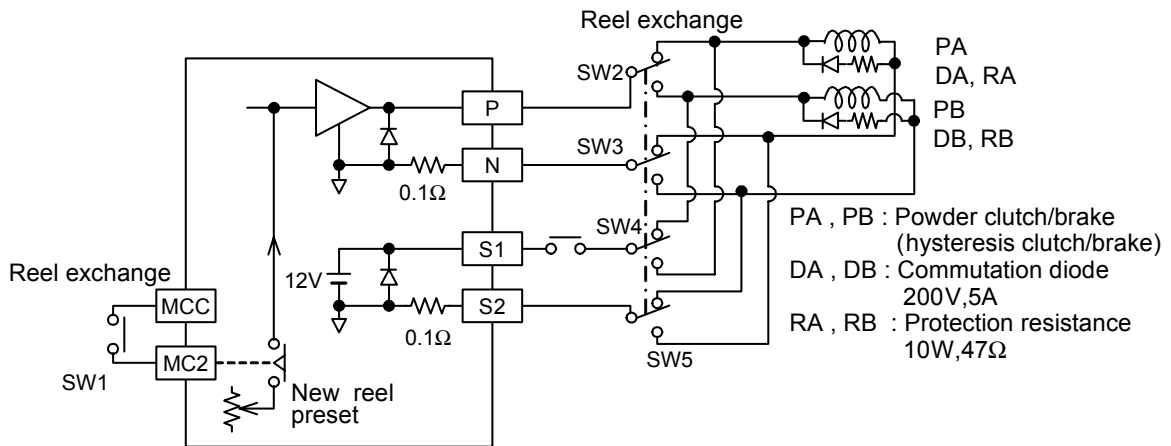

2. Setting

- Use the "REEL NUM." (number of reels) screen within "SWITCH" in the initial setting screen or the engineer screen to set reel switch-over or change the setting. Select "REELS" (multiple reels).



- Use the "NEW R.SET" (new reel set) screen on the operator screen to set or change the new reel preset value. Refer to the guideline for controller setting on page 15 to determine the settings.

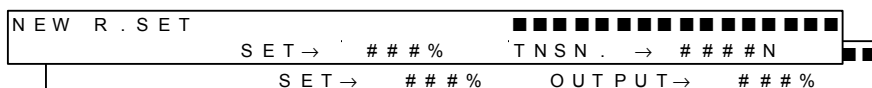

- Use the "PRESET T" screen within "REEL CHANGE" on the engineer screen to set or change the preset time. Include a margin in the preset value so that the tension feedback will not take place while the tension is unstable after switching the reels.

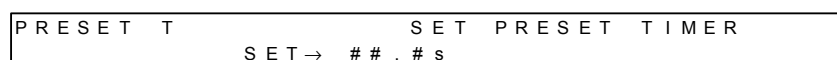

6.8 Powder winding, two-reel switching

In the two-reel operation, the contacts interlocking with reel change are connected to MC2. When this contact input changes from ON to OFF or OFF to ON, the control output is preset to the new reel preset value. When the preset timer times up, the automatic control starts here. Interlock this signal with the cutter operation. Switch SW1 at the same time as SW2 and SW3.

For the preparatory drive of the new reel, turn on the auxiliary power supply in a few seconds but not later than 10 seconds immediately before switching the reels.

In the two-reel winding operation, the mechanical loss cancel torque MLA and MLB are changed over. When it is OFF, the mechanical loss cancel value set to the reel A becomes valid. When it is ON, the mechanical loss cancel value set to the reel B is valid. This is effective when the mechanical loss of the reel A differs greatly from that of reel B. See page 35.

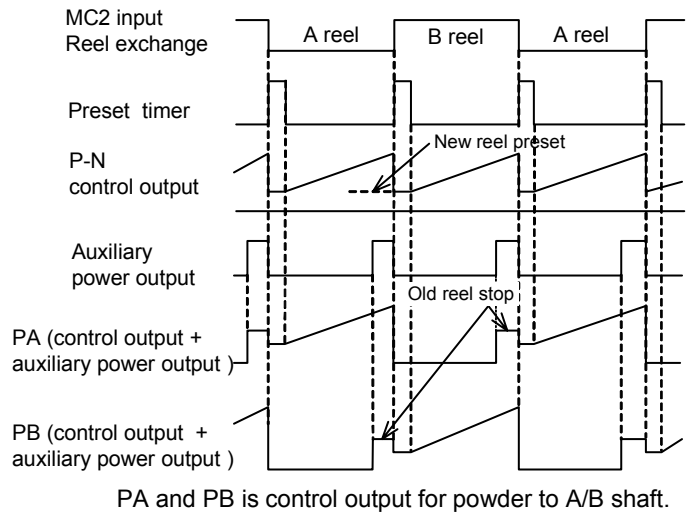

1. Connection of switch-over 2-reel powder

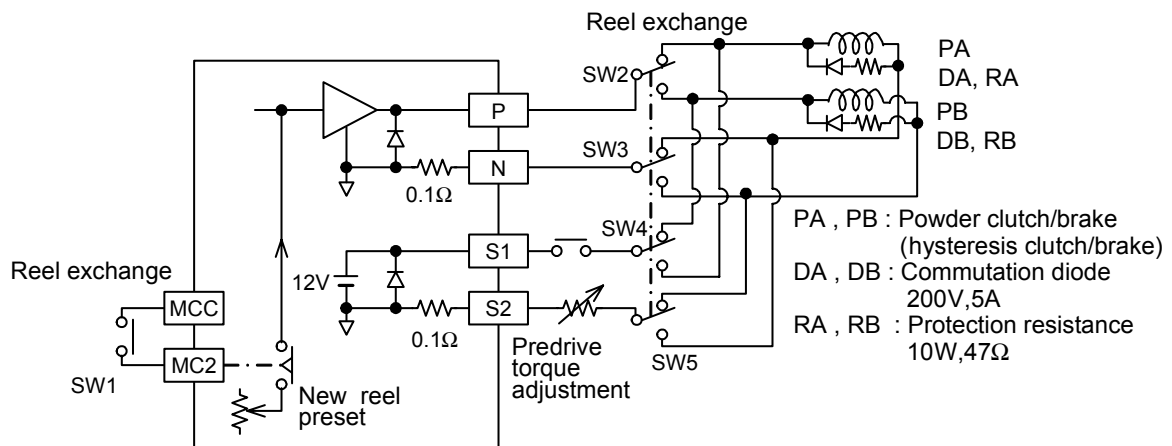

2. Setting

For setting the new reel preset value and preset time, refer to Section 6.7 "Powder unwinding, two-reels switching" on the previous page.

7.2 Control of excessive sag or tension in material during acceleration and deceleration

The following control is possible to limit the tension variation by material inertia during abrupt acceleration or deceleration of the machine.

1. Setting

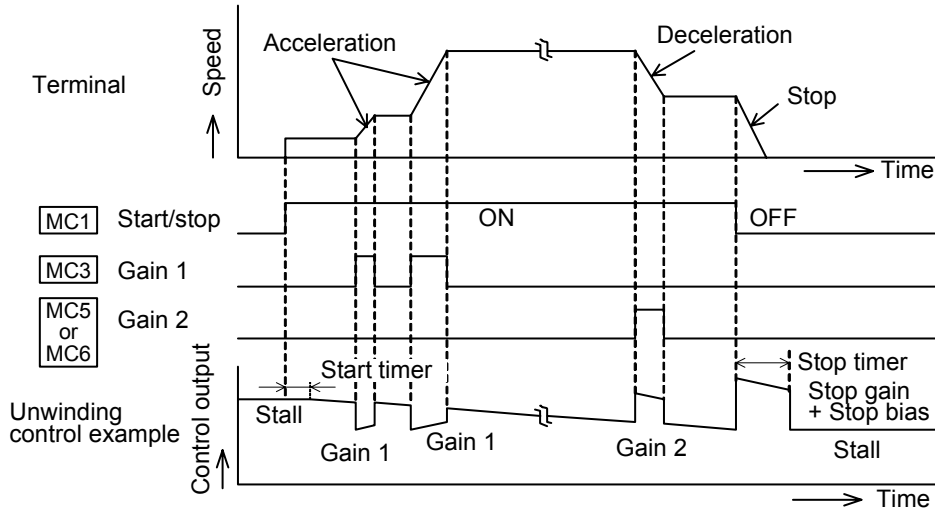

Gain 1 : While the input at terminal MC3 is on, the control output is 5 to 400% of the control output before the MC3 was turned on. This function makes the acceleration inertia compensation or deceleration inertia compensation possible.

In the unwinding control, for example, the acceleration inertia compensation is possible by turning on the MC3 input with controlling gain 1 at 100% or less during the acceleration. The deceleration inertia compensation is possible by turning it on and controlling the gain at 100% or more.

Gain 2 : While terminal MC5 or MC6 is on, the gain 2 settings are valid in the similar manner as described above.

As an example, gain 1 may be used during acceleration and gain 2 during deceleration.

2. Connection

- Use the micro signal switch commensurate with DC8V 4mA as the input contacts.
- Connect the gain 1 contact signal to MC3. Connect the gain 2 contact signal to MC5 or MC6, whichever is used.

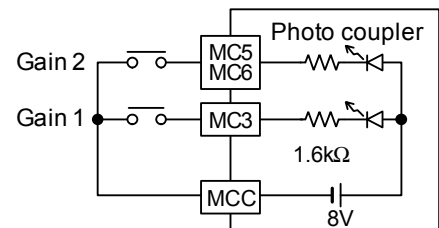

3. Setting

- Use the "OUT.GAIN" screen within "START / STOP" on the engineer screen to change the setting value of gain 1 and gain 2.

Use the numeral input keys to set the data

OUT . GAIN	SET OUTPUT GAIN
■ GAIN 1 → ### %	: □ GAIN 2 → ### %

- Use the "MC5" or "MC6" setting screen within "SWITCH" on the initial setting screen or the engineer screen to set the gain 2 contact or change settings.

MC 5	SELECT MC5 INPUT	
■ GAIN 2	: □ INCHNG	: □ OUT RMT . : □ CUT TRQ .

Select "GAIN2"

7.3 Control of excessive winding tension

1. Outline of taper control

Such control as to increase/decrease the working tension, depending on the change in winding diameter is called "Taper tension control", in which the tension is controlled in accordance with the preset pattern, to suit the change in winding diameter. This function is mainly used to prevent the material from winding too tight or too loose on the reel.

Following two methods are presently available to determine the current reel diameter:

- (1) By calculating internal reel diameter.
- (2) By entering the reel diameter externally through analog voltage (high precision taper tension control is possible).

In the internal reel diameter calculation, the reel diameter is calculated based on the torque control output. Since it is not necessary to enter the reel diameter, the accuracy is not very high.

Two methods are available to set the taper ratio as follows :

- (1) By setting the taper ratio (key entry) internally.
- (2) By entering the taper ratio externally through analog voltage.

Two methods are available to enter the taper curves as follows :

- (1) Linear line taper control.
- (2) Non-linear line taper control.

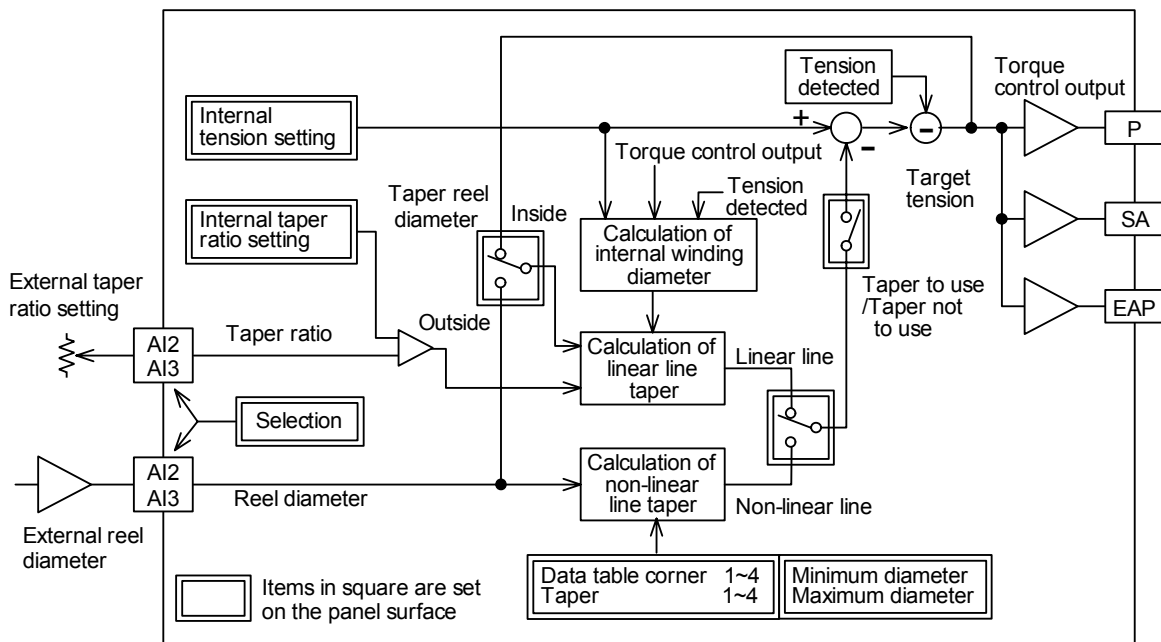

7.4 External reel diameter taper control

Entering the reel diameter externally results in high precision taper tension control.

Two methods are available to set the taper ratio as follows:

- (1) Setting the taper ratio by key entry (see page 29).
- (2) Setting the taper ratio externally through analog voltage.

Two methods are available to enter the taper curves as follows:

- (1) Linear line taper control.
- (2) Non-linear line taper control.

When touch lever is used

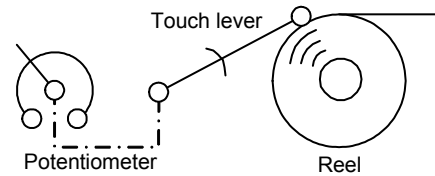

1. Connection

- Use the externally installed potentiometer as shown in the figure above to enter the reel diameter signal of 0V (minimum diameter) to 5V (maximum diameter) to terminals AI2 or AI3.
- When the external analog input is valid, "EXT." appears on the "DIA.MNT." (reel diameter monitor) screen.

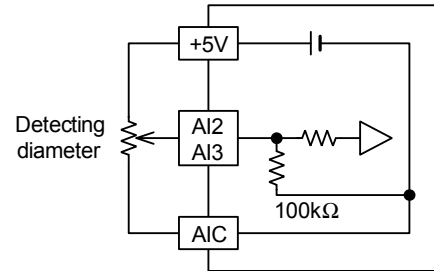

2. Setting

- For setting the external reel diameter taper, select "ON" on the "TAPER" screen on the initial setting screen or the engineer screen. Then select "EXT." (external) on the "TPR.DIA." (taper reel diameter) screen.

TAPER	SELECT TAPER TENSION CONTROL
<input type="checkbox"/> OFF	: <input checked="" type="checkbox"/> ON
▼	Select "ON"
TPR.DIA.	SELECT TAPER SIGNAL
<input type="checkbox"/> INT.	: <input checked="" type="checkbox"/> EXT.
▼	Select "EXT"
TAPER MD.	SELECT TAPER MODE
<input checked="" type="checkbox"/> LINEAR	: <input type="checkbox"/> NON - LINEAR

- Select which taper to use, the linear line taper or non-linear taper.
See the next page.

- To change the reel diameter input values by the external analog input, change the data on the "AI2" or "AI3" setting screen within "SWITCH" on the initial setting screen or the engineer screen.

AI2	SELECT AI2 ANALOG INPUT
<input checked="" type="checkbox"/> DIA.	: <input type="checkbox"/> STALL : <input type="checkbox"/> NEW R. : <input type="checkbox"/> TAPER : <input type="checkbox"/> TNSN.
_____	Select "DIA"

- To change the maximum or minimum value of the reel diameter, change the data on the "DIA.SET" screen within "REEL" on the initial setting screen or the engineer screen.
- The minimum and maximum diameters should be the machine specifications, and basically not changed according to the material.

DIA. SET	SET DIAMETER
<input checked="" type="checkbox"/> MIN. DIA → ### # mm φ	: <input type="checkbox"/> MAX. DIA → ### # φ

3. Linear line taper

- When the non-linear taper "LINEAR" is selected, the system enters in the linear line taper mode. The control takes place according to the taper ratio on the panel or to the taper ratio determined by the external controller, whichever is larger.
The taper ratio entered is the reduction rate from the set tension.
- The tension characteristics appears to be linear against the reel diameter signals as shown in the right figure.
- To set the taper ratio by key entry, use the taper set screen on the operator screen. For the taper ratio setting by the external controller, see page 38.

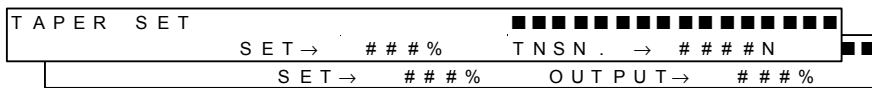
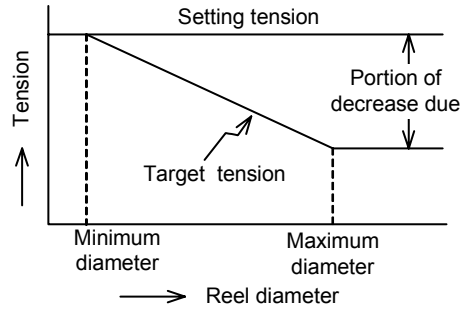

4. Non-linear line taper

- When the non-linear line data is set through the panel, the taper tension control takes place as follows:
Set the taper data as follows:
Corner 1 < corner 2 < corner 3 < corner 4
- When the 4-stage non-linear line taper control is not necessary, for instance, when the tension is constant from the minimum diameter to corner 1 and the linear line taper is given from corner 1, set the taper as shown in the right figure (Corner 1, Taper 1) (Corner 2, Taper 2). The linear line taper control may take place from corner 1 to corner 2.
Set the data as follows:
corner 1 ≥ Dmin, corner 2 ≥ Dmax
Not necessary to set data to corners 3 and 4.

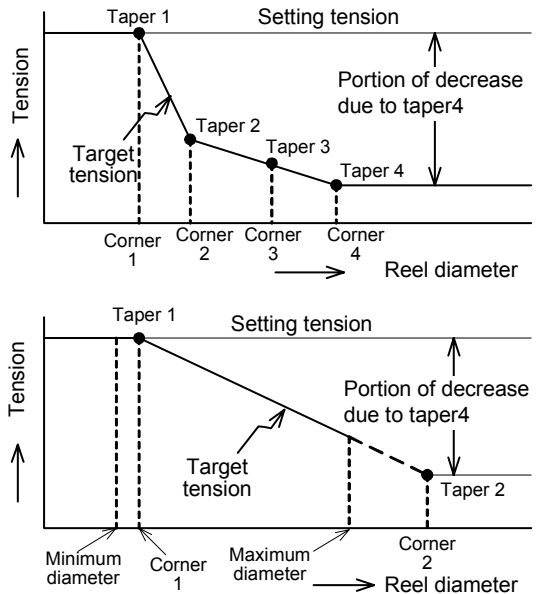

5. Display

The "TARGET" value in which the taper ratio is taken can be confirmed on the "TNSN.MNT." (tension monitor) screen of the operator screen.

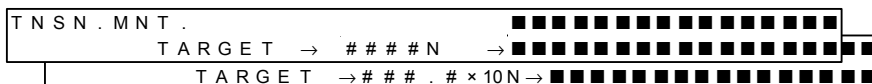

7.5 Change of control gains

The gains can be adjusted during operation. Adjust the auto-gain in the manual operation or automatic operation. To perform fine adjustment, adjust the manual gain. No need to change the gain if the tension is stable.

1. Automatic gain adjustment

- In the operational condition, when the specified output is added to the output in actual operation, the tension shows step-like changes. The control gain can be adjusted automatically based on the response characteristic of that tension.

Set the additive output on the automatic gain adjustment screen.

The right figure shows the operating characteristics of the automatic gain adjustment in the manual operation.

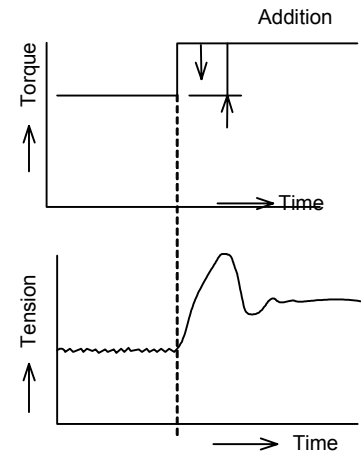

- To execute automatic gain adjustment
 - Operate the machine at the initial value of the control gain.
 - Select "AUTO" on the "GAIN" screen within "Gain" on the engineer screen.

```
GAIN          SELECT AUTO / MANUAL GAIN TUNING
■ AUTO       : □ MANUAL
```

Select "AUTO"



```
AUTO GTUNE   SET OFFSET OUTPUT
              SET→ ### %   OUTPUT→ ### %
```

Additional output

Output monitor of now



- Set the additive output (percent value for the maximum output) as large as possible on the premises it does not adversely affect the material. Press the enter key to set the value.
- When adjusting the automatic gain, the output increases instantaneously. When handling the material easily elongated or ruptured, set the additive output to a small value for adjustment.

```
AUTO GTUNE   EXECUTE AUTO GAIN TUNING
PUSH <ENTER> OR <CANCEL>
```

ENTER

```
AUTO GTUNE   EXECUTING AUTO GAIN TUNING
PUSH <CANCEL> AT STOP
```

Stand-by (for approximately 10sec)

```
AUTO GTUNE
AUTO GAIN TUNING COMPLETE!
```

- When errors generated during the automatic gain adjustment, add as large a torque as possible. An error will also be generated if accurate response waveforms cannot be obtained. Adjust the manual gain in such a case.

- Repeat the above steps two to three times for a higher accuracy.

1. Manual gain adjustment

- When fine adjustment of the gain is required, first set the integral time, then adjust the proportional gain according to the following procedure.
- The dead zone gain and dead zone width are not required to be changed in normal cases. However, adjust these values if it takes too long time to reach the target tension when starting the system, switching to a new reel, changing the tension settings.
- Select "MANUAL" on the "GAIN" screen within "GAIN" on the engineer screen.

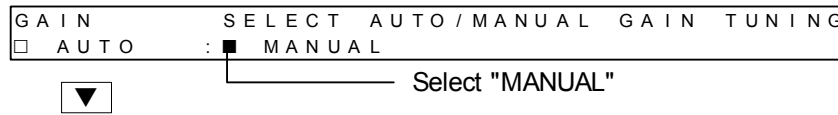

Set the value to as large a value as possible as long as the follow-up action is not too slow when changing the tension setting, or no hunting occurs while nearing the minimum diameter.
(Guideline: A value smaller by approximately 20% than the value at which hunting occurs.)

Reduce this value if deviation between the target tension and the actual tension remains.

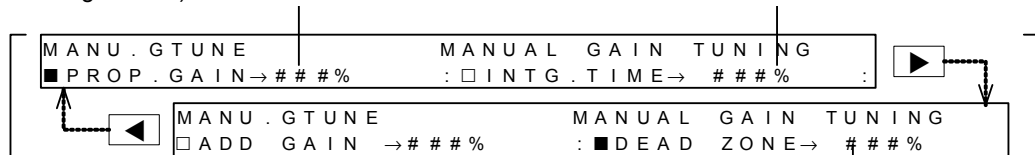

Not necessary to change in normal cases. If required to change, change the dead zone gain first to obtain the optimum value. Then, reduce the dead zone width to a smaller value.

[1] Integral time (Initial set value: 50%)

The integral time determines the time responsibility against the deviation between the target tension value and the operating tension value.

When a small value is set, the controllability is improved but hunting easily occurs. When a large value is set, the control is stabilized but the responsibility at the time when the unit is activated, the new axis is changed over, the tension set value is changed, etc. is deteriorated.

Set a large value with which the follow-up delay generated when the tension set value is changed is acceptable and hunting does not occur with a value near the minimum diameter.

[2] AProportional gain (Initial set value: 50%)

The proportional gain corrects the output in proportion to the deviation between the target tension value and the operating tension value.

When a large value is set, the target tension is reached faster but hunting easily occurs.

Set a value with which overshoot slightly remains when the target tension is changed.

The dead zone gain and the dead zone width are not required to be set (so that they remain in the initial setting) usually. However, if it takes considerable time to reach the target tension value when the unit is activated, the new axis is changed over, the tension set value is changed, etc., adjust them together with the integral time and the proportional gain.

[3] Dead zone width (Initial setting: 50%)

The dead zone width specifies the deviation generated when the proportional gain is changed over. When a small value is set, the responsibility becomes faster but hunting easily occurs.

[4] Dead zone gain (Initial setting: 0%)

When the deviation is larger than the dead zone width, the dead zone gain set here is added to the proportional gain to increase the gain.

When a large value is set, the time required until the deviation enters the dead zone range can be made shorter. However, if the set value is too large, hunting easily occurs. Enter a value with which appropriate responsibility can be obtained when combined with the dead zone width and the proportional gain.

7.6 Output of contact when running out of materials

This contact output can be used to detect an abnormality such as material running out.

The contact output will be turned on when the detected tension is smaller than the set parameter. When the parameter is set to zero, the contact output is OFF normally. If an abnormality occurs in the internal program, this contact output will be turned ON regardless of the settings or tension values.

The zero tension detection takes place with respect to the tension monitor display value. The zero tension detection timing therefore changes depending on the tension display filter setting.

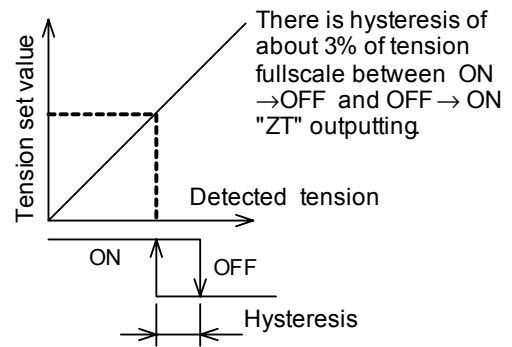

1. Connection

The capacity of the zero tension output contacts is as follows:

AC 250V 0.5A

DC 30V 0.5A

Connect loads matching with the capacity.

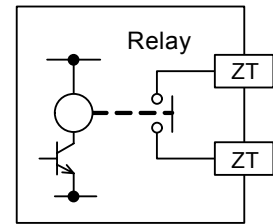

2. Setting

To use the zero tension output, set it on the "ZERO TNSN." screen within "TENSION" on the engineer screen.

ZERO TNSN.SET ZERO TENSION DETECT LEVEL
SET → ###N (0 = NOT USED)
SET → ###.# × 10N (0 = NOT USED)

7.7 Use for machines with frequent inching operation

This function is used to control the loss of tension by machine inching.

When this input is ON, the control output will not be smaller than the stall memory value.

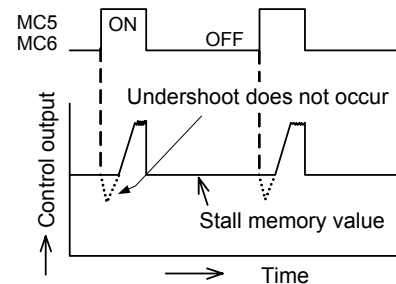

1. Connection

- Use a micro signal switch commensurate with DC8V 4 mA as the input contact.
- Connect the inching signals to the terminal MC5 or MC6 set as follows.

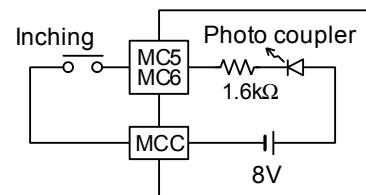

2. Setting

- To set the inching function, use the "MC5" or "MC6" setting screen within "SWITCH" on the initial setting screen or the engineer screen.

MC5	SELECT MC5 INPUT
<input type="checkbox"/> GAIN 2	<input checked="" type="checkbox"/> INCHNG : <input type="checkbox"/> OUT RMT : <input type="checkbox"/> CUT TRQ

Select "INCHNG"

7.10 Use of cut torque

In the automatic paper-jointing control, this function facilitates the material cutting while the cutter is in operation by fixing material tension at a greater value.

When the MC5 or MC6 contact input is ON, the control output is fixed and maintained at a constant level.

The lower limit of the control output is limited to the cut torque setting value.

When the reel change signal is entered, the value changes to the new reel preset value.

The reel change signal takes precedence over the cut torque. However, turn off the cut torque before the new reel preset timer times up.

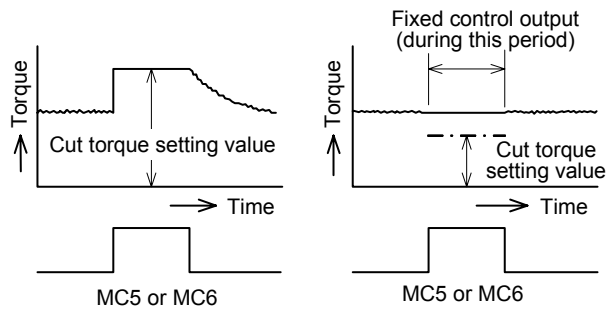

1. Connection

- Use a micro signal switch commensurate with DC8V 4 mA as the input contacts.
- Connect the cut torque to the terminal MC5 or MC6 set as follows.

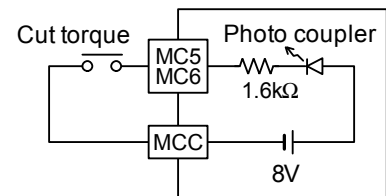

2. Setting

- Use the "MC5" or "MC6" setting screen within "SWITCH" on the initial setting screen or the engineer screen to set or change the cut torque setting.

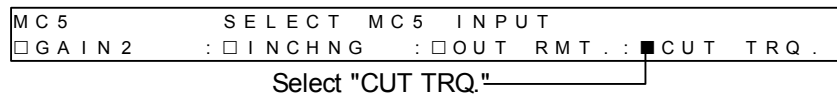

7.11 Reduction of variation in tension readout

To reduce variation in the tension readout, select "Display filter" within "Tension" on the engineer screen. Increase the value to make the response slower. This makes the tension reading more stable and comfortable when it varies quickly.

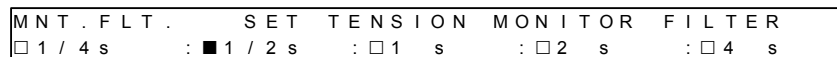

8.3 Varies stall

1. Connection

- Given 0 to 5V input, the stall setting value becomes 0 to 100% output. Connect this signal to the terminal A12 or A13.
- When the stall memory reset input [MC4] is turned ON or the output on/off switch on the panel changes from ON to OFF, this value is preset in the stall memory value.
- This input is valid if it is greater than the internal stall settings. See the notes on the page 37.

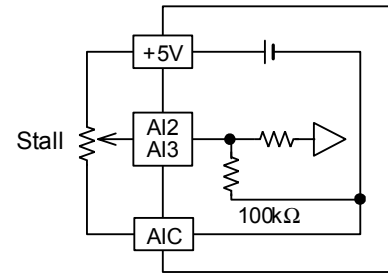

2. Setting

- To change the stall setting input to the setting by the external analog input, use the "A12" or "A13" setting screen within "SWITCH" on the initial setting screen or the engineer screen.

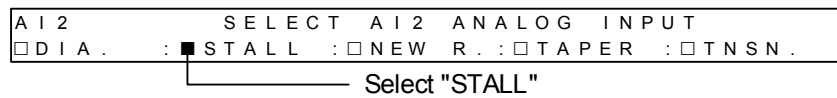

3. Display

When the external analog input is valid message "EXT." appears on the "Stall set" screen as shown below. If "EXT." is gone, the key setting value is greater and is therefore valid

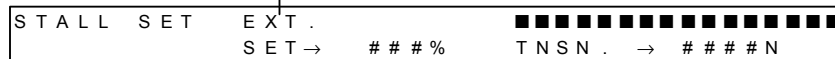

8.4 Varies taper ratio

1. Connection

- Given 0 to 5V input by, for example, an external controller, the taper ratio setting value becomes 0 to 80% when the reel diameter is set internally or 0 to 100% when the reel diameter is set externally. Connect this input to the terminal A12 or A13.
- This input is valid if it is greater than the taper ratio setting value by the key entry. See the notes on the page 37.

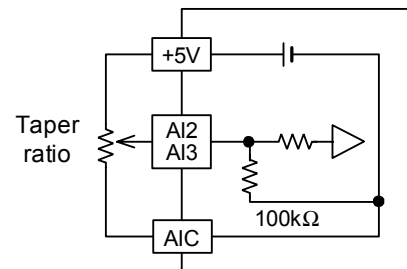

2. Setting

- To change the stall setting value input to the setting by the external analog input, use the "A12" or "A13" setting screen within "SWITCH" on the initial setting screen or the engineer screen.

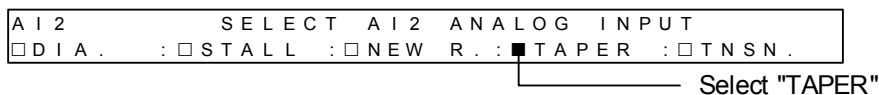

3. Display

When the external analog input is valid message "EXT." appears on the "Taper set" screen as shown below. If "EXT." is gone, the key setting value is greater and is therefore valid

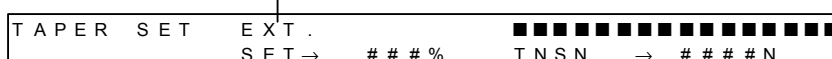

8.5 Varies new reel torque

1. Connection

- When the system changes to the new reel in the two-reel operation, the external input of 0 to 5V sets the control output from 0 to 100%.
 - Connect this input to the terminal A12 or A13.
- This input is valid if it is greater than the internal new reel preset value. See the notes on the page 37.
- In the two-reel operation, the system performs this input designation and gives the switch-over signal from reel change input MC2.

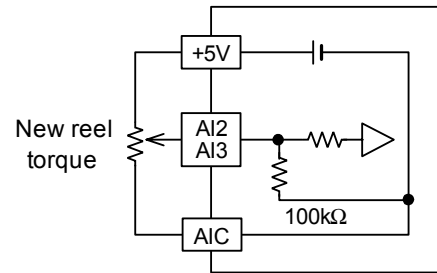

2. Setting

- To enter the new reel torque by the external analog input, use the "A12" or "A13" setting screen within "SWITCH" on the initial setting screen or the engineer screen.



3. Display

When the external analog input is valid message "EXT." appears on the "new reel set" screen as shown below. If "EXT." is gone, the key setting is greater and is therefore valid

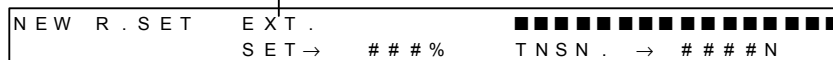

8.6 Enters external tension data

1. Connection

- Signals of 0 to 5V (zero to full scale tension) from the auxiliary tension detector are entered to the terminal A12 or A13 through LM-10TA type tension amplifier or similar device.
- This input is compared with the signal detected value by the tension detector which is connected directly to the LE-40MTA-E. The automatic control is carried out using the greater value.
- If Mitsubishi tension detector is not used, carry out zero adjustment according to the instruction on page 10. In this case, short-circuit the terminals GRR and WHR and terminals GH1 and WH1.

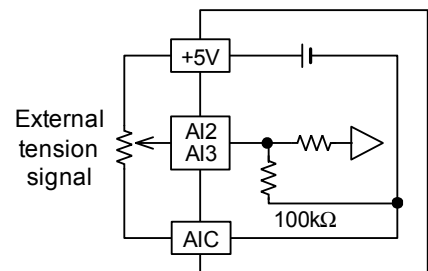

2. Setting

- To enter the external tension signal by the external analog input, use the "A12" or "A13" setting screen within "SWITCH" on the initial setting screen or the engineer screen.

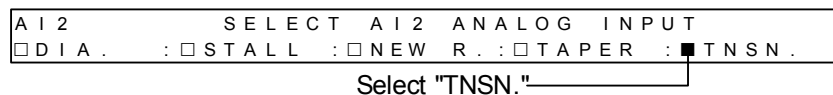

3. Display

- The 4-digit, 7-segment display shows the tension for confirmation.

9. Other functions

9.1 Records tension data

Corresponding to the tension detection from zero to full scale, the output from 0 to 5V is generated. The full scale tension is set by the parameter.

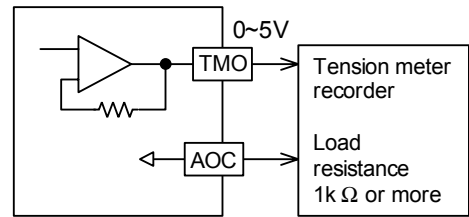

1. Connection

- Connect this signal between TMO and AOC.
- The load resistance should be 1 kΩ or greater.

2. Setting

- The output filter can be adjusted to 1/4, 1/2, 1, 2 or 4 seconds by the parameter.
- To change the response characteristic of the TMO tension monitor output, select "TMO FLT." within "TENSION" on the engineer screen. Increasing the value slows the response characteristic.

```
TMO FLT. SET TMO OUTPUT FILTER
 1 / 4 s :  1 / 2 s :  1 s :  2 s :  4 s
```

9.2 Monitors input and output condition

To check condition of the contacts and analog data input and output, use the "CONTACTS" screen or similar one within "OTHERS" on the engineer screen.

(Contact input / Output monitor screen)

```
CONTACTS CONTACTS MONITOR
 MC 1 :  MC 2 :  MC 3 :  MC 4 :  MC 5 :  MC 6 :  Z T
```



(Analog input monitor screen)

```
MONITOR1 SIGNAL INPUT MONITOR
A I 1 → # . # V : A I 2 → # . # V : A I 3 → # . # V
```



(Analog output monitor screen)

```
MONITOR2 SIGNAL OUTPUT MONITOR
S A → # . # V : T M O → # . # V : N R O → # . # V
```

9.3 Returns all settings to the initial factory settings

To reset all the settings to the factory settings, use the "MEMORY INIT." screen within "OTHERS" on the engineer screen. Note that the data having been established will disappear.

```
MEMORY INIT.
PUSH <ENTER> OR <CANCEL>
```

ENTER

```
MEMORY INIT. START
PUSH <ENTER>
```

ENTER

After several second

```
MEMORY INIT. COMPLETE
START THE INITIAL TUNING
```



Initial setting screen

After completing the initialization, refer to page 8 and after to re-establish the initial settings

9.4 Copies data settings to other controller

- All the set data saved in the tension controller except the external input from the trimmer or others and internal monitor values can be written, read and compared between the memory cassette FX-EEPROM - 4 (or FX-EEPROM-8).
- By transferring the data from the memory cassette in which the operation constants and parameters in accordance with each material to the tension controller, the unit can be activated easily at a local site.

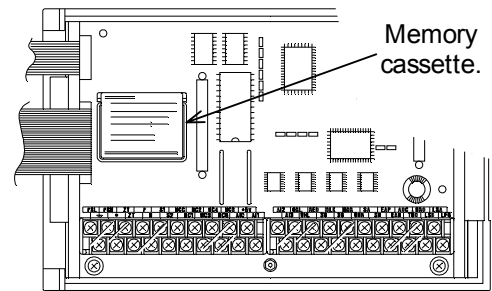

1. Storing data on cassette

Read the data from the original controller to copy the settings.

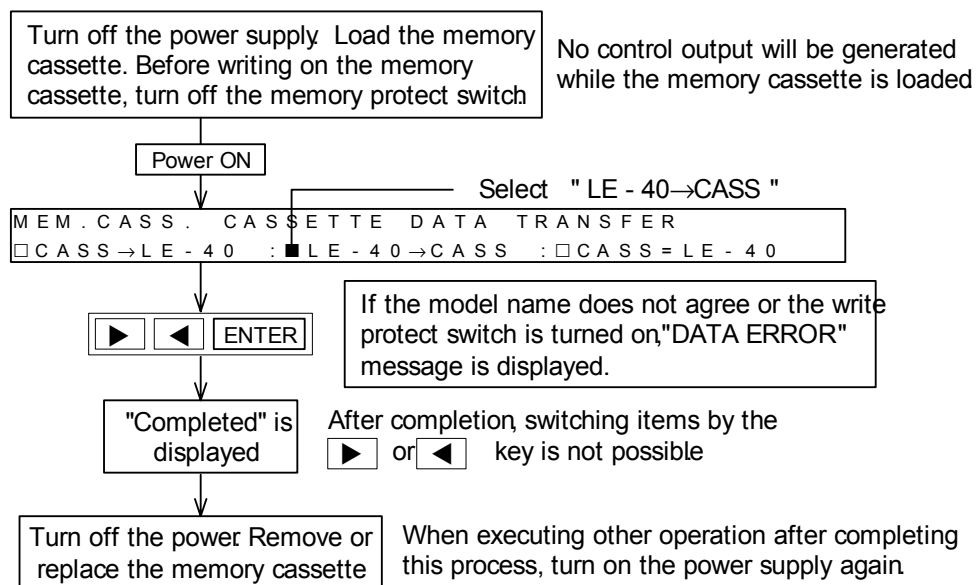

2. Writing data on cassette

Writes the settings of the original controller on the new controller.

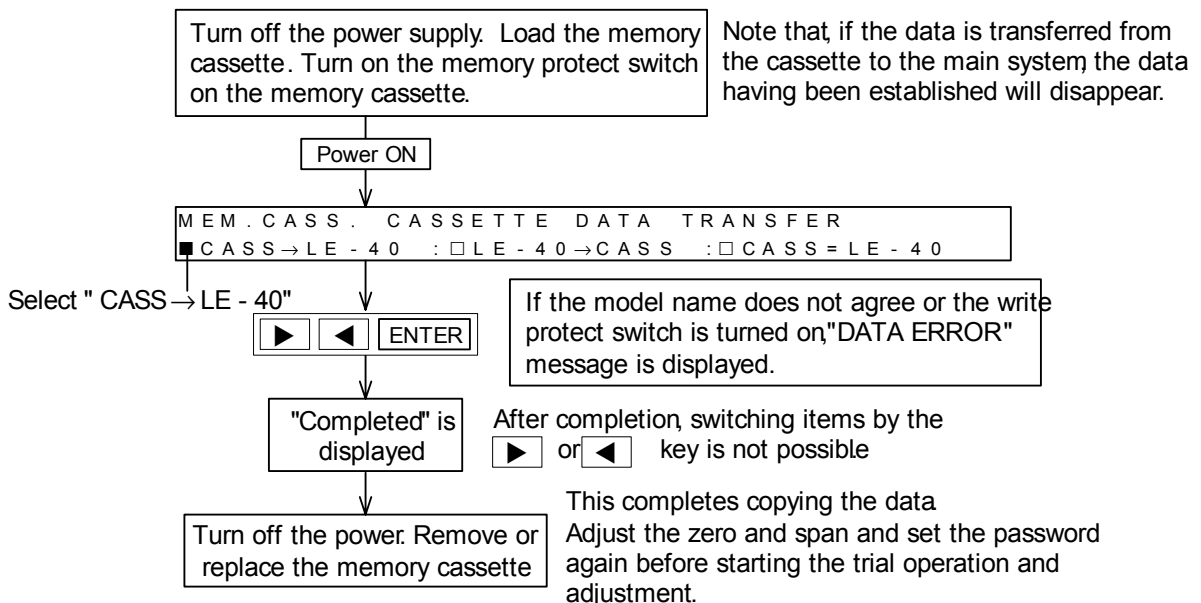

10. Inspection and Maintenance

10.1 Initial inspection

1. Confirmation of selection

- Before starting operation, make sure that the tension detector, actuator, power-amplifier, servo amplifier and E / P regulator are selected correctly.
- The P-N output of the tension controller LE-40MTA-E is designed as 24 VDC, 4 A or less. The actuator capacity is selected based on the line speed multiplied by the operating tension. A larger tension can be set in the LE-40MTA-E. However, in the case, the actuator may be burned out. Make sure that the operator is instructed appropriately as to the allowable maximum operating tension.
- If the set tension is too small, the tension fluctuation become too large compared with the operation tension when the unit is started or stopped, and operation may be difficult. Make sure that the operator is instructed appropriately as to the allowable minimum operating tension also. The guideline of the minimum operating tension is shown below.

2. Operation sequence

- Check the operation sequence and emergency stop sequence. Especially when the servo motor is used as actuator, the motor may become out of order if the material is cut. Use the material cut detector and the zero tension detection output of the LE-40MTA-E together , and set the speed limit input of the motor to 0 when the material is cut.

3. Wiring check

- Erroneous connection of the power terminal (Pay attention to the phase order in the motor system also.), contact of the DC I/O cable with the power cable, and short-circuit of the output cable may cause serious damage. Before turning on the power, make sure that the power and ground are connected correctly and that the I/O cable is wired correctly.
- Never perform the megger test (measurement of insulation resistance).

10.2 Maintenance

- Check periodically the following items:
 - The temperature inside the panel is not abnormally high due to heat generating substance or direct sunlight.
 - Dusts and conductive dusts are not inserted into the panel.
 - Incorrect wiring, loose terminals and other abnormality are not detected.
- It is ideal to adjust the zero point and span in the tension detector again at each periodic inspection. Especially when a tension detector used has a larger rated load compared with the actual tension, the mechanical stress of the tension detector may contribute considerably to aging deterioration.
- The zero tension relay offers the service life of 500,000 (five hundred thousands) times against the load of 35 VA or less. Accordingly, no problem will occur in the zero tension relay if it is not actuated abnormally frequently.

10.3 Error display

The table below shows the error messages displayed on the screen and the countermeasures.

Type	Message	Trouble shooting	
Hardware	OUTPUT OFF	Turn on the OUTPUT ON/OFF switch on the panel or OUT remote switch.	
	AUX.OUT.IS SHORT	Open the auxiliary power output terminal(S1~S2) and check the output voltage. If the output voltage is DC 12V, check the load (less 2A or not) and outer wiring. If the output voltage is not obtained, the LE-40MTA-E is defective.	
System parameter	REEL ERROR	Check *2 and *3 of selection item described in page 50.	When completion of the initial setting is confirmed or when the AUTO switch is pressed while the operation /stop input is turned off, error check is performed.
	SET PARAMETER	The minimum diameter and maximum diameter must be set in accordance with the reel diameter input of 0~ 5V.	
Tension detector Zero/Span adjustment	THE DETECTION ROLLER IS TOO HEAVY!	It is thought that the mass of the tension detection roller is heavier than the rated load of the tension detector. Check the mass of the detection roller. It is necessary to select the detector again if necessary. Refer to page 45 for details.	
	SPAN TUNING TARGET WEIGHT IS TOO LIGHT!	The weight at the span adjustment is too light in 1/3 or less of the tension full scales. Make the weight heavy and execute the span adjustment again.	
	DETECTED LOAD IS TOO LIGHT!	The output voltage of the tension detector is too low. Because the rated load of the tension detector is larger than that of the drive tension, it is necessary to select the tension detector again. Refer to page 45.	
	CHANGE WH _ - GR _ CONNECT WIRE!	The wiring for the tension detector is opposite. Exchange the terminals [GRR] and [WHR]each other as well as the terminals [GRL]and [WHL]each other. Refer to the part of the tension detector on page 14 for details.	
	NO LOAD TO THE DETECTION ROLLER!	Put the weight on the tension detection roller and execute the adjustment again.	
	DETECTED LOAD IS TOO HEAVY!	The output voltage of the tension detector is too high. Because the rated load of the tension detector is smaller than that of the drive tension, it is necessary to select the tension detector again. Refer to page 45.	
Data transfer between memory cassette	CASSETTE TYPE ERROR	Use the memory cassette FX-EEPROM-4/8 sold separately.	
	WRITE PROTECT ON. TURN OFF SW	Turn off the write protect switch in the memory cassette.	
	DATA ERROR	After writing or reading, data is automatically collated. If this error message is displayed,replace the memory cassette.	

10.4 Unintended operation

Check the abnormality of the major components during trial operation and adjustment and during actual operation using the following procedure.

Item	Problem	Disposal
Power supply	When the POWER switch is turned ON, the POWER LED is not lit.	<ul style="list-style-type: none"> • Make sure the supply voltage between the terminals [PSL] and [PSN] is 100 to 240VAC (+10% to -15%), 50/60 Hz. If this value is not correct, perform the correct wiring. • The fuse may be melted by insertion of foreign objects or abnormal loads. If simply replacing the fuse may not solve the problem. Contact our service department.
Tension display and abnormal tension	On the display, the tension value or the unit of the tension flashes.	<ul style="list-style-type: none"> • The tension signal from the tension detector is too high. The applied load may exceed the rated load of the tension detector. Lower the tension set value. • Check the rated load of the tension detector. If no problem is detected, increase the full-scale tension value. (After changing the full-scale tension value, be sure to tune the zero point and the span.)
	When restarting after stopping the material, the tension reading goes beyond the scale from the beginning.	<ul style="list-style-type: none"> • Turn ON or OFF the [MC1] input signal depending on the run/stop status of the machine. If the [MC1] input signal is kept at on status, restarting operation may send out the maximum control output, and an extremely high tension may be applied. • When stopping the machine, if the turning-OFF timing of the [MC1] input signal is delayed, the control output may be extremely increased, and an extremely high tension may be applied at starting operation. To prevent this problem, be sure to turn OFF the [MC1] input signal when stopping the machine.
	The output increases while the machine halts.	<ul style="list-style-type: none"> • The [MC1] input signal may not be turned OFF. • While the machine is stopped, be sure to turn off the [MC1] input signal.
	After replacement of the material, an extremely high or low tension is applied.	<ul style="list-style-type: none"> • Check that the output set for the OFF status of the [RUN] input signal is optimum for the reel diameter of the replaced material. • Reset the stall memory.
	Fluctuating tension control	<ul style="list-style-type: none"> • Check whether similar fluctuations occurs during manual operation. • Fluctuations during manual operation is generally caused by changes in tension as a result of machine vibration, mechanical loss, etc. In this case please check the machine. • If fluctuations do not occur during manual operation, this is generally caused by high control gain set by the LE-40MTA-E tension controller. In this case, please adjust the control gain factor refer to Sec. 7.5.
Actuator	Output cannot be obtained in the manual mode.	<ul style="list-style-type: none"> • Make sure that the OUTPUT ON/OFF switch is turned on. • When 0 to 24 V output is obtained between the terminals [P] and [N] by the manual torque setting, check the wiring to the powder clutch/brake. When no abnormality is detected, the clutch/brake is defective or selected inappropriately. • If the output voltage is not obtained in the no-load condition when the power is changed from off to on, the LE-40MTA-E is defective. If the short-circuit protection function between the terminals [P] and [N] is actuated, the unit becomes the normal condition when the wiring is corrected and the power is turned on again. • If 0~5V output is not obtained between the terminals [SA] and [SN] and the terminals [NRO] and [AOC], remove the external load (1kΩ or more) and check whether 0~ 5V is obtained. • If 4~20mA output is not obtained between the terminals [EAP] and [EAN], remove the E/P regulator (470Ω or less), connect the ammeter between the terminals [EAP] and [EAN], then check whether 4~20mA output is obtained. • While the memory cassette is attached, the control output is not generated.

Item	Problem	Disposal
Input signal	The contact signal and the analog voltage signal are not input properly.	<ul style="list-style-type: none"> Compare the ON/OFF status of the input contact signal with the status shown on the monitor screen. In addition, check the input contact for poor contact. If the input signal is properly turned ON and OFF but the ON/OFF status is not displayed on the monitor, the LE-40MTA-E tension controller is defective. Compare the voltage of the analog input terminal with the voltage value displayed on the monitor. Also check that noise is not influencing the input line.
Others	Material gets loose during acceleration or deceleration.	The material tends to get loose if the acceleration/deceleration time is too short or the material inertia is too high. Use gain 1 or gain 2 to compensate the inertia during acceleration and deceleration.
	Material is displaced or gets too tight during winding.	The taper control is recommended.

Check the system as per the following procedure if the zero/span adjustment would not complete.

Item	Problem	Disposal
Tension detector	Zero adjustment is not possible.	<ul style="list-style-type: none"> If the voltage between the terminals [RED] and [BLK] is not approximately 5.0 VDC, remove the wiring of this terminal and measure the voltage. If the specified voltage is not obtained, the LE-40MTA-E is defective. If the specified voltage is obtained, the external wiring or tension detector is defective. Remove the wiring in the tension detector. Short-circuit the terminals [WHR] and [GRR] as well as the terminals [WHL] and [GRL]. If zero adjustment is not possible still, the LE-40MTA-E is defective. Connect the terminals [RED] and [BLK] exclusively to the tension detector. If the voltage between the white and green cables in the tension detector is 120 mVDC (150mV DC x 0.8) or less with which the current is not applied in the material and zero adjustment is not possible, the LE-40MTA-E is defective. If the measured voltage exceeds 120mV, the tension detector selected is not appropriate. (The tare weight is 80% or more of the rated load.)
	Check the wiring in accordance with page 5.	
	Span adjustment is not possible.	<ul style="list-style-type: none"> Perform zero adjustment at first. Connect the terminals [RED] and [BLK] exclusively to the tension detector. Measure the voltage between the white and green cables in the tension detector. When span adjustment is not possible even if the difference between the voltage measured when the material tension is set to 0 and the voltage measured when the material tension is set to full scale value is 30mV (150mVDC x 0.2) or more, the LE-40MTA-E is defective. When the difference in voltage is less than 30mV, the tension load applied on the tension detector is insufficient and the tension detector selected is not appropriate. Even if the span adjustment is normally completed, the tension detection error increases. Use a tension detector having a less rated load. If the load is changed while the span is adjusted, adjustment may become disabled.
	Check the wiring in accordance with page 5.	

11. Specifications

11.1 I / O Specifications

Items		Terminal	Specifications	
Power supplies	Input	PSL	100 ~ 240V AC +10 ~ -15% 50/60 Hz 400VA	
		PSN	Power fuse (250V 8A) built in Allowable instantaneous power interruption:10ms	
	Output	S1(+)	Auxiliary power supply: 12 VDC, 2 A, Rating: 10 s	
		S2(-)		
		RED(+)	Power supply for tension detectors	
		BLK(-)		
		+5V(+)	Service power supply for external trimmer 5V DC, 50mA or less	
		AIC(-)		
Contact signals	Input	MCC	Contact input common terminal	
		MC1	Operation/stop ON=Automatic operation, OFF=Stop	
		MC2	Reel exchange signal OFF=Reel A, ON=Reel B	
		MC3	Gain 1 Gain 1 is effective during ON.	
		MC4	Stall memory reset One-shot input for approx. 0.5 s	
		MC5	Gain2 : Gain 2 is effective during ON. Inching : Lower output limit is effective. Stall memory update is stopped.	
		MC6	OUT remote : Control output is ON during ON. Cut torque : Lower output limit is effective during ON (for cutter). Each function is assigned by parameter.	
	Output	ZT	<ul style="list-style-type: none"> • Zero tension detection output. Set value : 0~1999 N (199.9 kgf) • Output becomes ON when tension does not exceed set value. • Output is always OFF when "0" is set. (However, output becomes ON regardless of set value and tension when watch dog timer is actuated.) • 250V AC, 0.5A or 30V DC, 0.5A 	
		ZT		
	Analog signals	Input	GRL	Left
WHL				
GRR			Right	
WHR				
AI1		External tension setting 0 ~ 5 VDC corresponding to 0 ~ full-scale tension		
AIC		Internal resistance : 100 kΩ Recommended trimmer: 10 kΩ		

Items		Terminal	Specifications		
Analog signals	Input	A12	Diameter : Reel diameter signal for external taper control. 0 ~ 5 V corresponding to minimum value to maximum value. Stall : External stall setting signal. 0 ~ 5 V corresponding to 0 ~ 100% output torque. New reel : New reel preset 0 ~ 5 V corresponding to 0 ~ 100% output torque. Taper ratio: External taper ratio setting 0 ~ 5 V corresponding to: <ul style="list-style-type: none"> • 0 ~ 80% (internal diameter taper) • 0 ~ 100% (external diameter taper) 		
		A13	Tension : Auxiliary tension input 0 ~ 5V corresponding to 0 to full-scale tension • Function is specified by parameter. • Internal resistance:100k Ω		
	Output	SA	Control signal output		For power amplifier servo amplifier
		SN	<ul style="list-style-type: none"> • Powder mode : 0 ~ 5 VDC • AC servo mode : 0 ~ ± 5 VDC • Load resistance : 1 kΩ or more 		
		NRO	New reel preset output		
		AOC	<ul style="list-style-type: none"> • Effective exclusively when "REELS" mode is selected. • 0 ~ 5 VDC • Load resistance : 1 kΩ or more 		
		TMO	Tension monitor output		For tension meter recorder
		AOC	<ul style="list-style-type: none"> • Filter can be adjusted by parameter. • 0 ~ 5 VDC • Load resistance : 1 kΩ or more 		
		EAP	Control signal output for E/P regulator		For air clutch air brake
		EAN	<ul style="list-style-type: none"> • 4 ~ 20 mADC • Load resistance : 470 Ω or less 		
P	Power output for 24 VDC system powder clutch/brake and hysteresis clutch/brake.				
N	<ul style="list-style-type: none"> • 0 ~ 24 VDC, 4 A or less 				

11.2 I / O interface

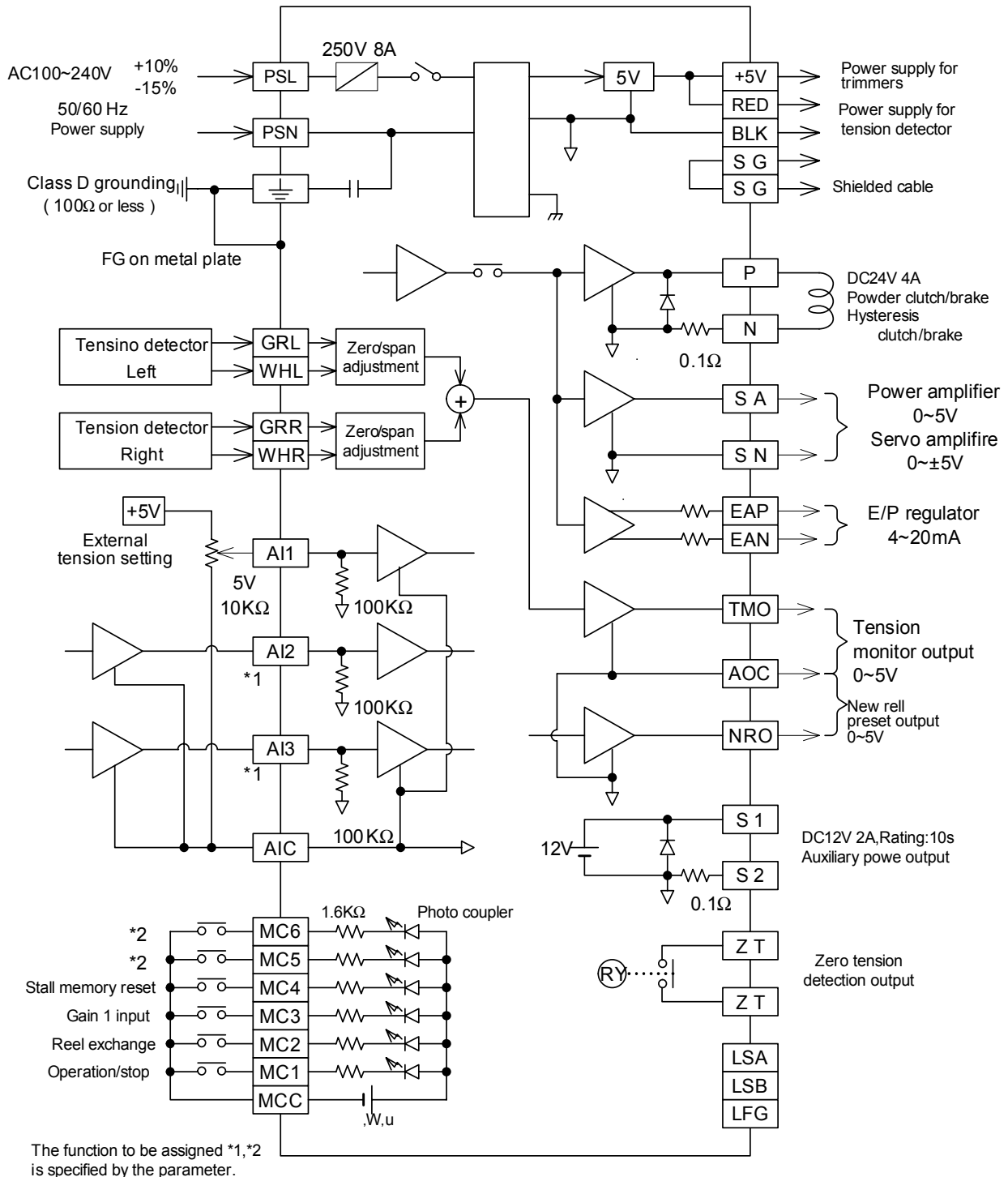

PSL	PSN	ZT	P	SI	MCC	MC2	MC4	MC6	+5V
⊕	•	ZT	N	S2	MC1	MC3	MC5	AIC	AI1

AI2	GRL	RED	BLK	GRR	SA	EAP	AOC	NRO	LSA
AI3	WHL	SG	SG	WHR	SN	EAN	TMO	LSB	LFG

11.3 Various setting values

The items indicated with white letters on a black ground must be always set. Another items are set in accordance with the function used.

Set items	Set values	Unit	Set range		Initial value	*1 Memory cassette transfer	*2 Setting during operation	Mainly refer page		
			Minimum	Maximum						
Tension	Tension setting	Tension set value (N)	N	0.1 ,1 or 10 ~ FS tension		—	NG	○	18	
		Tension set value(×10N)	N	0.01 ,0.1 or 1 ~ FS tension		—	NG	○	18	
	Full scale tension	Full scale value	—	1	1999	500	○	×	12	
		Decimal point (N)	—	0.1, 1.0 or 10		×1	○	×	12	
		Decimal point (×10N)	—	0.01 ,0.1 or 1		×0.1	○	×	12	
	Tension detector	Zero adjustment	—	0	0	0	NG	×	12	
		Span adjustment target value	N ×10N	1 digit ~ FS tension (1/3 or more of FS tension)		500 50.0	○	×	12	
	Filter	Display time constant	s	1/4, 1/2, 1, 2, or 4		1/2	○	○	35	
		TMO output time constant	s			1/2	○	○	42	
	Zero tension detection value	Zero tension (N)	N	0	1999	0	○	×	36	
		Zero tension (×10N)	×10N	0	199.9	0.0	○	×	36	
	Manual setting	Manual set value	%	0	100	—	○	○	18	
Taper	Linear taper	Taper ratio(int. diameter)	%	0	80	0	○	○	31	
		Taper ratio(ext. diameter)	%	0	100	0	○	○	32	
	Non-linear taper	Corner 1~4	mmφ	0	2000	0	○	○	33	
		Taper 1~4	%	0	100	0	○	○	33	
Start	Stall	Stall set value	%	0	100	20	○	○	15	
	Timer	Start timer	s	0.0	10.0	4.0	○	○	28	
Output gain	Gain 1	%	5	400	100	○	○	29		
	Gain 2	%	5	400	100	○	○	29		
New reel /old reel switch-over	New reel preset value		%	0	100	50	○	○	25	
	Preset timer	s	0.0	30.0	4.0	○	○	25		
	Old reel cut torque		%	0	100	10	○	○	38	
Stop control	Stop timer		s	0.0	100.0	6.0	○	○	28	
	Stop gain		%	5	400	100	○	○	28	
	Stop bias		%	0	50	0	○	○	28	
Mechanical loss correction	Reel A	Powder mode	%	0	100	0	○	○	37	
		AC servo mode	%	-50	100	0	○	○	37	
	Reel B	Powder mode	%	0	100	0	○	○	37	
		AC servo mode	%	-50	100	0	○	○	37	
Reel diameter	Minimum diameter		mmφ	0	2000	100	○	×	32	
	Maximum diameter		mmφ	Minimum set diameter	2000	1000	○	×	32	
Control gain	Manual setting	Proportional gain (P gain)		%	0	100	50	○	○	35
		Integral time		%	1	100	50	○	○	35
		Dead zone gain		%	0	100-P gain	0	○	○	35
		Dead zone width		%	0	100	50	○	○	35
	Automatic gain setting	Addition torque		%	0	100	20	○	○	34
Password			—	0	32767	4095	×	○	10	

*1 : These parameter avail setting data copy by using memory cassette.

*2 : The setting of the item marked with "×" on the " Setting during operation " column cannot be changed while the MC input is turned on.

11.4 Selection item and analog data

1. Selection item

----- The items cannot set during operation.

Set item	Description	Initial set	Memory casset transfer *1	Setting during operation	Mainly refer page	
Selection item	Control while stop timer	feed back / Fixed	feed back	○	×	28
	Unit of tension	×10N / N	N	○	×	10
	Control reel	Unwinding / Winding / Feed	Unwinding	○	×	11
	Number of reels	One reel / Multi reels	One reel	○	×	11
	Taper control	OFF / ON	OFF	○	×	31
	Taper signal	Internal / External	Internal	○	×	31
	Taper mode	Linear / Nonlinear	Linear	○	×	32
	Actuator	Powder / Servo	Powder	○	×	11
	Stall mode	Key set / MANUAL vol.	MANUAL	○	×	16
	Stall reset	MC4 / MC4+OUT SW.	MC4+OUT SW.	○	×	15
	AI2/AI3 setting	Diameter / Stall / New reel preset / Taper ratio / Ext. tension	Not set	○	×	48 *2
	MC5/MC6 setting	Gain 2 / Inching / OUT remote / Cut torque	Not set	○	×	48 *3
	Number of detectors	2 / 1	2	○	×	12
	Automatic gain	Automatic / Manual	Manual	○	×	34

*1 : Refer to the note in the previous page.

*2 : Setting of MC5, MC6

When the control reel is set to one reel or the feed reel, never set the [cut torque] to MC5 or MC6. Set the [cut torque] exclusively when multiple reels are selected.

*3 : Setting of AI2, AI3

When the control reel is set to the feed reel, never set the [taper ratio] or the [diameter] to AI2 or AI3. Set the [taper ratio] or the [diameter] exclusively when the control reel is set to [winding] or [unwinding]. When the taper signals set to [external], make sure to set the winding diameter to AI2 or AI3. When the control reel is set to one reel or the feed reel, never set the [new reel preset] to AI2 or AI3. Set the [new reel preset] exclusively when multiple reel are selected.

2. Analog data

Name	Unit	Digital data for analog value of 0~5V	Increment	Remark	
Internal	Manual torque	%	0 ~ 100	1	Terminals AI2 and AI3 are set by parameters.
	Tension setting	N	0 ~ full scale tension	1	
×10N		0.1			
External	Tension setting(AI1)	N	0 ~ full scale tension	1	
		×10N		0.1	
	Tension detector (auxiliary)	N	0 ~ full scale tension	1	
		×10N		0.1	
	Taper ratio setting	%	0 ~ 80%(0=Set tension):Int.diameter	1	
			0 ~ 100%(0=Set tension):Ext.diameter		
Stall setting	%	0 ~ 100%	1		
New reel preset	%	0 ~ 100%	1		
Diameter input	mmφ	min. diameter ~ max. diameterAO2000	11		

- These inputs are always valid even if set screen is not displayed.
- These analog values are digitized by 12-bit A/D converter.

3. Monitor data

The monitor data contains the following items, and is not saved if power is interrupted.

- Tension monitor, total (N,×10N)
- Tension monitor, left (N,×10N)
- Tension monitor, right (N,×10N)
- Control output(0~100%)
- Tension, target (N,×10N)
Value based on the set tension while taking the decrease ratio of the taper tension into account.
- Reel diameter input(min. diameter ~ max. diameter)

11.5 Outside dimensions and general specification

1. Outside dimensions

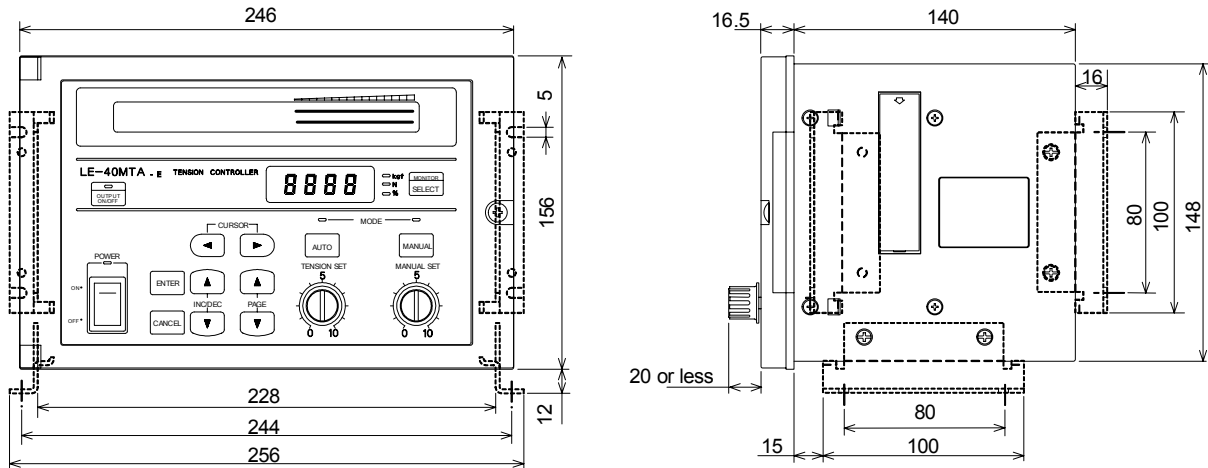

Accessories

- Main unit mounting plate : One pair
- Screws fixing main unit and mounting legs : M4 × 10 ,4screws

Weight : Approximately 3.5 kg
 Painting color : Munsell 7.5Y 7.5/1

Screws of 10 mm or more are not applicable because such screws may make contact with parts inside the main unit.

When the unit is installed on the floor or wall, use these screws to fix the main unit and mounting legs.

2. General and environmental specifications

Ambient temperature	0 ~ 40°C during operation	
Ambient humidity	80% RH or less (no condensation) during operation	
Vibration resistance	In accordance with JIS C0040. 10 to 55 Hz, 0.5mm (4. 9m / s ² maximum), 2 hours in each of three axis directions .	
Impact resistance	In accordance with JIS C0041. 98m / s ² , 3 times in each of three axis directions.	
Supply noise resistance	By noise simulator with 1,000 Vp-p noise voltage, 1 μs noise width and 30 to 100 Hz cycle.	
Withstand voltage	1,500V AC, 1 minute	Entire terminals as a whole andbetween the ground terminal.
Insulation resistance	5MΩ or more by 500V DC megger	
Grounding	Solid grounding (100Ωor less)	
Operating atmosphere	No corrosive gas and little dust	
Power switch cycles	Less than 20,000 times	

11.6 Supplement

1. Rough estimate of minimum drive tension

The minimum drive tension which can be driven in torque controller can be requested by next outline type. When this is graphed, it is a right picture.

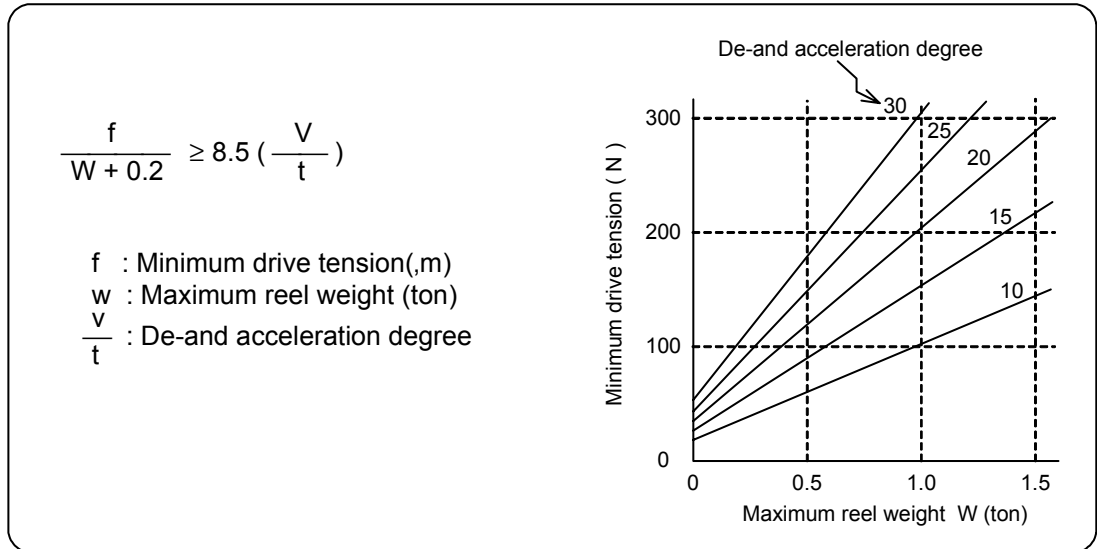

2. Sliding timer

The function is used to execute the operation smoothly, for prevention of undershoot due to sudden decrease of tension when the mode is changed from manual control mode to the automatic control mode. It is determined automatically during operation.

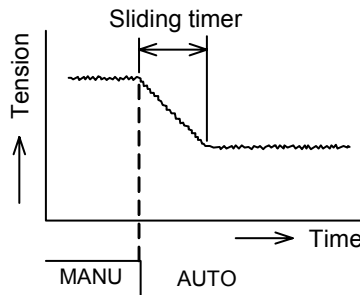

The sliding timer is determined automatically in accordance with the following equation.

$$\begin{aligned} \text{Sliding timer} &= \{ \text{(Tension detected during manual operation)} - \text{(Target tension for automatic operation)} \} \\ &\quad / \text{full-scale tension} \times 25 \text{ sec.} \end{aligned}$$